

## IQ5 I/O Module

### IQ5-IO I/O Module



#### Description

The IQ5-IO range of I/O modules are designed for use with the IQ5 controller, to provide input and output channel connection points.

A comprehensive choice of I/O types is available including universal inputs/outputs (UIO), digital inputs (DI), digital/relay outputs (DO). A 'hand-off -auto' variant (8DO-HOA) is also available, offering manual override of module outputs. Integral I/O bus connectors allow easy and convenient 'side-by-side' module installation or, by using wiring adapters, modules can be installed up to 300 meters apart.

#### Features

- Universal input/output, digital input, digital output variants
- Hand-off -auto option (on 8DO-HOA)
- Up to 300 I/O channels per controller (subject to licence)
- T1L high-speed secure bus connection to controller
- Side-by-side or remote connection options
- Up to 300 metres (1000 ft) between cable connected modules
- Powered from controller or external PSU
- Two part I/O connectors for easy installation/commissioning
- Surface or DIN rail mounting, DIN 19 size 2 standard enclosure

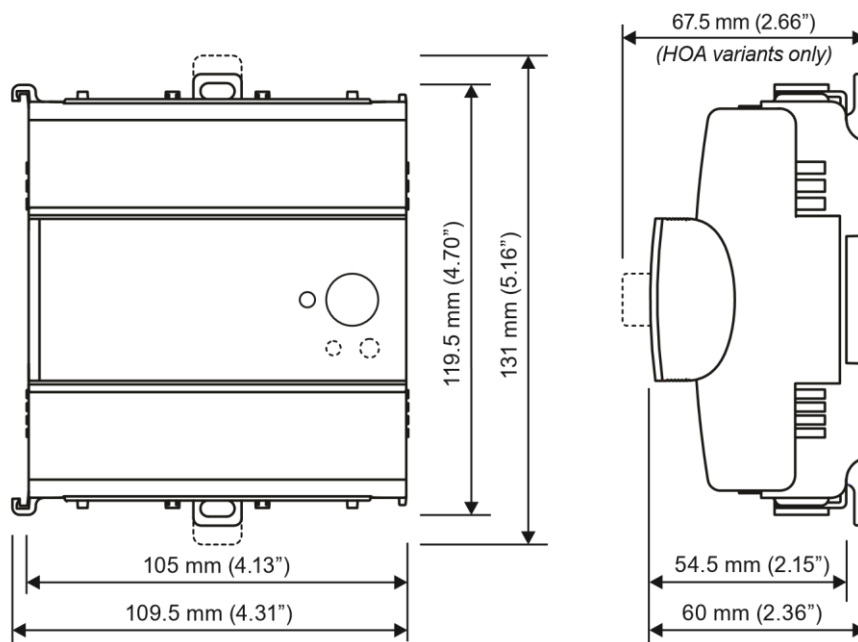

Physical

FUNCTIONALITY

HARDWARE

The range of IQ5-IO Expansion Modules comprises the following variants:

**16UIO**  
16 Universal Inputs/Outputs  
Channels 1-8

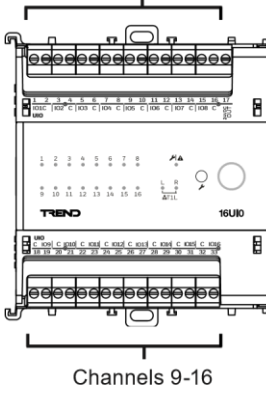

**16DI**  
16 Digital Inputs  
Channels 1-8

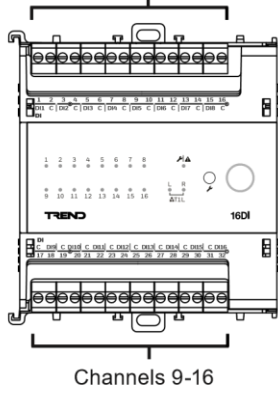

**8DO**  
8 Digital/Relay Outputs  
Channels 1-4

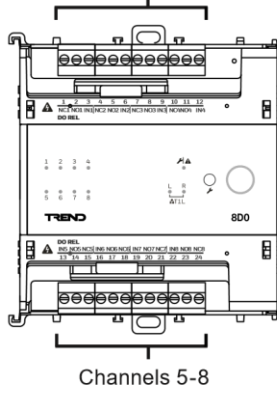

**8DO-HOA**  
8 Digital/Relay Outputs, HOA  
Channels 1-4

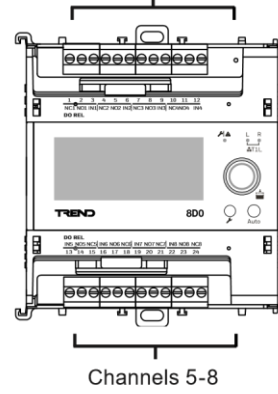

**8UIO-105**  
8 Universal Inputs/Outputs  
Channels 1-4

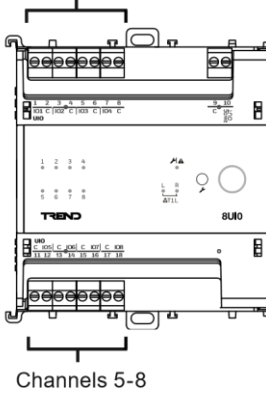

Note: All modules shown with terminal covers removed.

## Enclosure

Each IQ5-IO Module is housed in a polycarbonate enclosure compatible with the DIN43880 and DIN 19 size 2 standard and with a complimentary styling to the IQ5 controller.

Integral clips on the back of the case enable the unit to be clipped on to (and quickly released from) a standard TS35 DIN rail, or be used to mount the unit directly to any suitable flat surface.

IQ5-IO Modules must be installed in a secondary enclosure with a minimum protective rating of IP20 (or equivalent) or mounted outside normal reach (e.g. in a plenum).

A module may be mounted horizontally or vertically but not upside down or on its back:

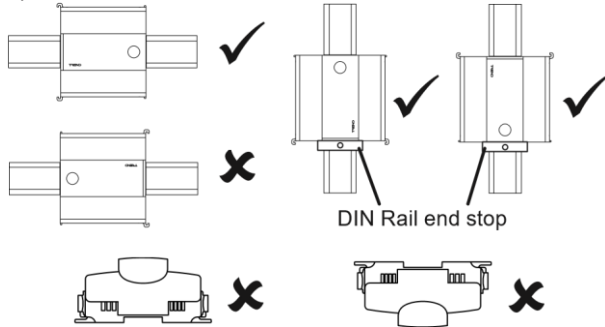

Removable clip-on polycarbonate covers provide access to the various onboard terminal connections.

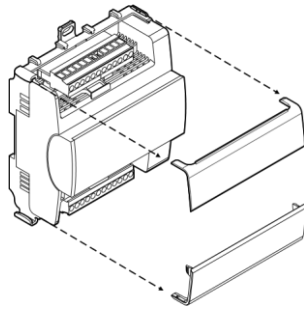

Spare covers are available (see 'Order Codes' on page 13)

## Terminal Connectors

Connections for the various I/O channels are via two-part plugable screw terminal connectors which are supplied as standard with the modules and available in packs for spares. Optional connectors with push-fit terminals are also available (see 'Order Codes' on page 13).

Screw terminal plug

Push-fit terminal plug

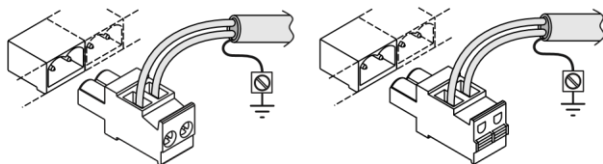

Function	Connector Type
Universal Input/Output (UIO)	2-way*
Digital Input (DI)	2-way
Digital/Relay Output (DO)	3-way

\*On the 16UIO, input IO8 uses a 3-way connector with the extra terminal providing a connection to the 24 Vdc supply output.

## Auxiliary Terminal Block

Optional terminal blocks are available that can be clipped on to an IO module to provide additional common terminals. These can be used (for example) to provide multiple 24 Vdc connections from the single 24 Vdc terminal on the 16UIO or 8UIO module, or to provide ground/earth connections for cable screens.

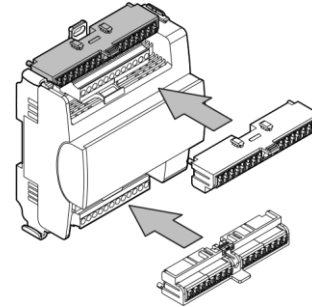

The **AUX-TRM-16** has 16 push-fit terminals, configured as two common groups of 8 with a maximum load of 12 A.

If more terminals are needed the connectors can be 'doublestacked'.

## Input/Output Channels

The following types of input and output channel are supported:

- Universal Input/Output (UIO)
- Digital Inputs (DI)
- Digital/Relay Output (DO)

## Cable Screening

The use of screened cable for input and/or output connections is optional and not generally required unless the cable passes through electrically noisy environments.

If screened cable is used the screen must be connected to the local panel/enclosure ground and left unterminated at the far end.

## Universal Input/Output (UIO)

These channels will function in one of the following modes:

- thermistor input,
- voltage input,
- digital input,
- current input,
- analogue output.

The input/output mode of each channel is set by the strategy configuration in the controller.

**Thermistor input:** Used for a thermistor (e.g. NTC (2K, 3K, 10K, 20K), PT100, PT1000) potentiometer (0 to 300 kΩ) or fan speed control. The thermistor bridge resistor is 12 kΩ with a bridge supply 3.3 V.

Example wiring

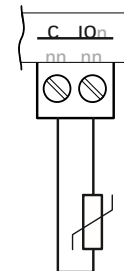

**Voltage input:** Used with a 0 to 10 Vdc or 2 to 10 Vdc source.

Example wiring

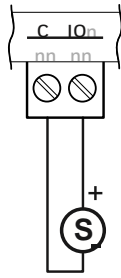

**Digital input:** Used for a volt free contact, logic circuit (e.g. TTL, CMOS), open collector (transistor) or open drain (FET).

Example wiring

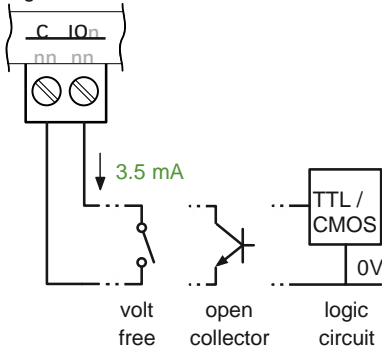

The volt free contact has a nominal wetting current of 3.5 mA. The input is ON when the contact is closed.

An open collector or open drain must be able to sink 3.5 mA. The input is ON when the transistor or FET conducts.

A logic circuit must be able to sink 3.5 mA. The input will be ON when the applied voltage is less than 2 Vdc (minimum 0 V). A voltage of greater than 4 Vdc (maximum 40 Vdc) will turn the input OFF. Voltage levels between 2 and 4 Vdc may cause indeterminate operation.

The input can be configured for pulse count operation (maximum 100 Hz with 50% / 50% duty cycle, 5 ms ON / 5 ms OFF).

**Current input:** Used for 0 or 4 to 20 mA sources. May be either loop powered (from onboard 24VDC OUT terminal) or externally powered.

Example wiring - loop

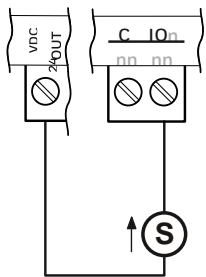

Example wiring - external

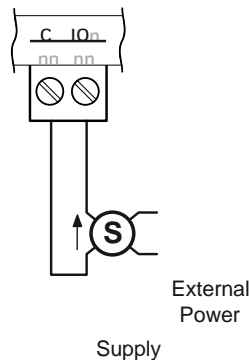

Note: The 24VDC OUT terminal can source up to 75 mA.

**Analogue output:** Provides either a variable voltage output (0 to 11 Vdc, 0 to 10 Vdc, 1 to 10 Vdc or 2 to 10 Vdc) or variable current output (0 to 20 mA or 4 to 20 mA).

Example wiring

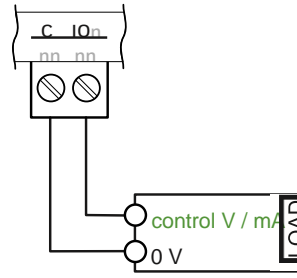

**Digital Input (DI)**

These channels are compatible with the following input devices:

- volt free contact (e.g. switch or relay),
- logic circuit (e.g. TTL, CMOS),
- open collector (transistor) or open drain (FET), or
- 24 Vac circuit.

Example wiring

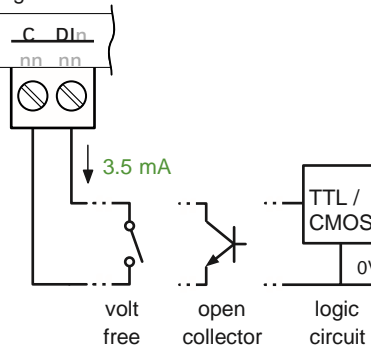

The volt free contact has a nominal wetting current of 3.5 mA. The input is ON when the contact is closed.

An open collector or open drain must be able to sink 3.5 mA. The input is ON when the transistor or FET conducts.

A logic circuit must be able to sink 3.5 mA. The input will be ON when the applied voltage is less than 2 Vdc (minimum 0 V). A voltage greater than 4 Vdc (maximum 40 Vdc) or open circuit will turn the input OFF. Voltage levels between 2 and 4 Vdc may cause indeterminate operation.

The input can be configured for pulse count operation (maximum 100 Hz with 50% / 50% duty cycle, 5 ms ON / 5 ms OFF).

Digital inputs can also be used to monitor the state of a 24 Vac circuit (e.g. to determine if a relay or actuator is on or off).

Example wiring

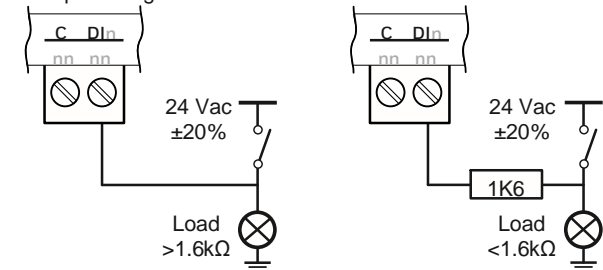

In the above example the input will be ON when the load is powered. If the load impedance is less than 1.6 kΩ (e.g. a filament lamp or relay coil) then a 1.6 kΩ resistor must be fitted in series with the input.

**Digital/Relay Output (DO)**

These channels provide a single pole dry contact changeover relay.

Example wiring

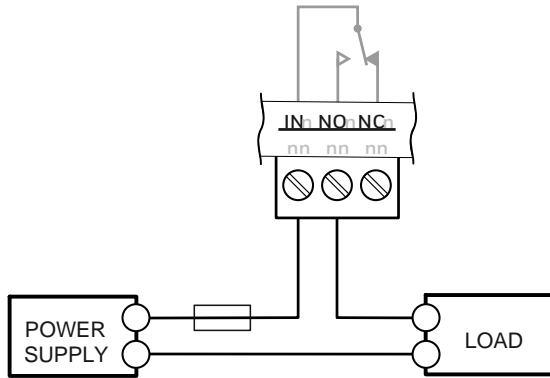

Ensure that external circuits are suitably protected against fault currents that would exceed the ratings for the switching circuits provided in this product.

The relay contacts close (i.e. NO makes with IN) when the output channel is ON.

*Note: The relay on channel 5 on the 8DO and 8DO/HOA has a higher contact rating than the other channels (see "Digital/Relay Outputs (DO)" on page 11 for further details).*

An optional 4-way plug-in jumper (IO-JUMPER-4) can be inserted adjacent to the connectors which will link the IN terminals. This enables a common supply to be used on channels 1 to 4 or 5 to 8:

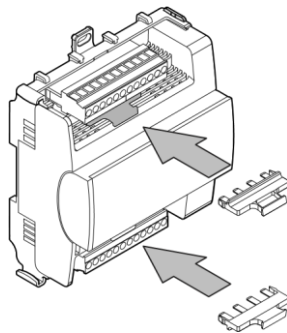

*Note: If required, pins can be removed from the 4-way jumper to prevent a certain channel from being linked. For example, remove the pin from channel 4 position to only have channels 1, 2 and 3 linked.*

**T1L IO Bus**

IQ5-IO modules interconnect with each other and the IQ5 controller via the T1L IO bus, which comprises the following power and signal connections:

- 24 Vac (50/60Hz) or 24 Vdc
- 0 V
- Ground
- Data Hi
- Data Lo
- Screen

Modules can be slotted together, adjacent to the controller (or other I/O modules) with inter-module connections being made via integral spring connectors.

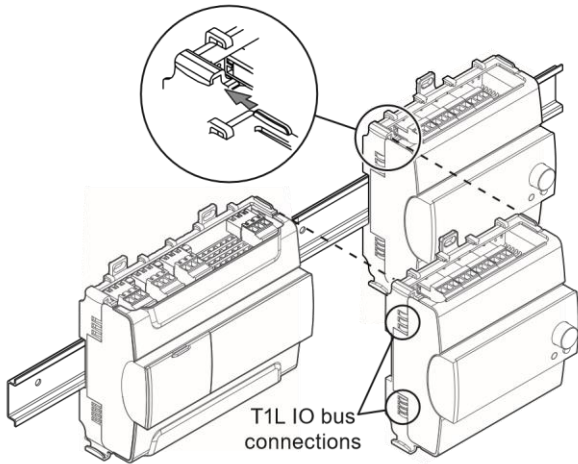

Note: Modules can easily be removed without disturbing adjacent modules.

Modules can also be mounted remotely from the controller (or from neighbouring I/O modules) and connected to the I/O bus by using IQ5-IO-ADPT wiring adapters and suitable cable.

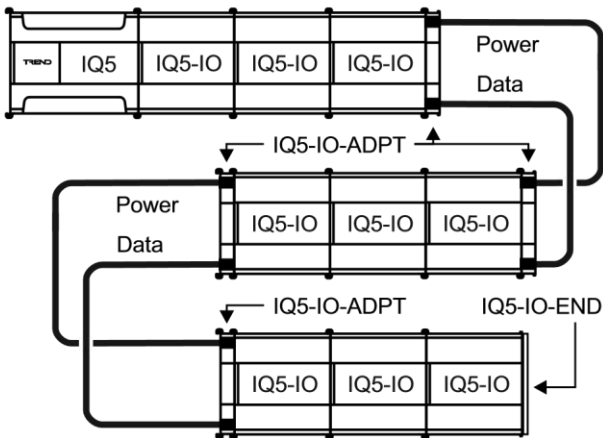

Note: The IQ5-IO-ADPT wiring adapter includes a self-resetting fuse and transient voltage suppression that protects the I/O bus from over-current and over-voltage conditions caused by electrical transients or incorrect wiring. No protection is provided against accidental connection of mains voltages.

Cabling between modules on the I/O bus may be wired from right to left side, right to right or left to left, as long as correct bus polarity is maintained. Spurs are not permitted.

A cover plate (IQ5-IO-END) must be fitted to the last module on the bus, to protect the exposed bus connectors.

Note: A cover is supplied with each IQ5 controller which can be used for this purpose. A pack of spare covers is also available.

**Maximum I/O Bus Length**

Where cabled interconnections are used each wired segment may be up to 300 metres (1000 feet) using high quality cable (recommended type Belden 3084A or 7895A).

Note: One or more additional power supplies may be required on long cable runs to prevent excessive voltage drop on the power line (see "Module Power Supply" on page 6).

**Maximum Number of Modules**

Up to 254 modules can be connected to the I/O bus. The maximum number of IO channels is subject to the number of points licenced on the controller.

**Module Power Supply**

I/O modules can typically be powered from the controller via the I/O bus supply. This bus supply is derived from the controller's 24 Vac/dc supply and, therefore, the maximum current available to the I/O bus depends upon other current demands placed on the controller.

The maximum current required by each type of I/O module is listed in the table below – these values can be used to estimate the total current required by the I/O bus:

Module	Device Status	Current (Max)		Power (Max)	
		24 Vac (mA)	24 Vdc (mA)	24 Vac (VA)	24 Vdc (W)
16UIO	All channels set to AO 20 mA	1083	500	26	12
8UIO		708	333	17	8
16DI	All inputs ON	375	146	9	3.5
8DO 8DO-HOA	All relays ON	333	125	8	3

Where the total current requirement of the I/O bus exceeds the maximum available from the controller, one or more additional 24 Vac/dc power supplies may be installed. Additional supplies may also be required in the following circumstances:

- at the end of a long I/O bus cable run, to prevent voltage drop on the bus supply (minimum 19V supply required),
- where the current flow through the power line of any one module would exceed the maximum of 1 A, thus requiring the I/O bus power line to be split or segmented.

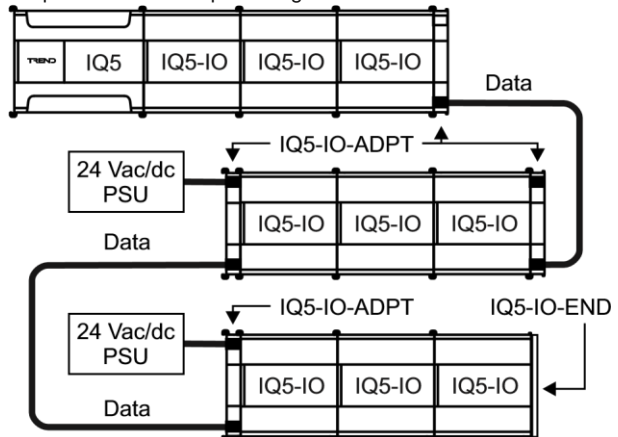

**Additional Power Supplies**

**Important:** Not permitted for UL compliant installations.

Where it is necessary to install an additional power supply along the I/O bus, the supply output must be isolated from earth (ground). The supply unit must also comply with the relevant EMC and safety standards.

Note: Trend offer a range of DIN rail mounted auxiliary power supplies that are suitable for this purpose.

The I/O wiring adapter (IQ5-IO-ADPT) is used to make the connection of external power supply units to the I/O bus as shown below:



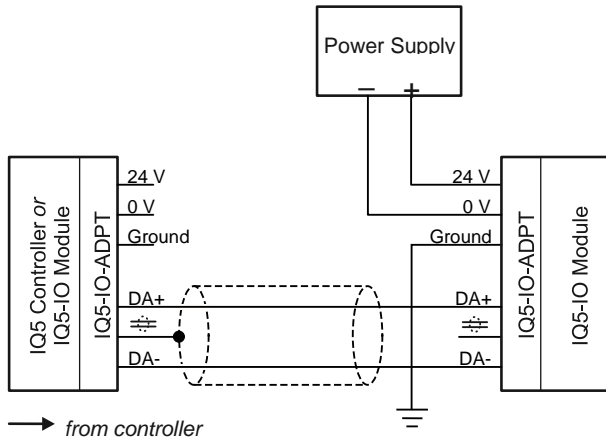

**Important:** The 24 Vdc connection from the previous module must not be made. The 0 V connection must be made when an external supply is used and the 0 V line must be continuous for the entire length of the I/O bus.

**Earthing/Grounding Arrangements**

It is important that correct earthing/grounding is provided for the controller and modules on the I/O bus.

The I/O bus ground is connected to earth/ground via the controller. Modules located within the same secondary enclosure are earthed/grounded via the I/O bus ground connection.

Where modules are located in different secondary enclosures or where I/O bus cables exceed 1 m (39"), a local earth/ground connection must be provided. For further details refer to the IQ5-IO Expansion Modules Installation Instructions - Mounting (TG201484).

All DIN rails must be earthed/grounded.

**I/O Module Addressing**

Each module on the I/O bus must be assigned a unique address (XXXXXXX).

The controller will automatically attempt to match each physical I/O module with its corresponding strategy I/O module and set its address accordingly.

Module addresses can be configured within the controller strategy, or manually changed using IQ®SET or the controller's web page interface. Refer to the IQ5 Configuration Manual (TE201486) for further details on addressing.

**Indicators**

Various indicators are provided giving feedback on the operational status of the module and its inputs/outputs.

**General Indicators** (all variants):

Indicator	Colour	Function
	Green Amber Red	Device status. Green indicates normal operation. Amber or Red indicates a XXXXXXX.
	Green	Service status.
	Green	Status of the T1L I/O bus connected to the left (L) or right (R) side of the module.

**Input/Output Indicators** (depending on module type):

Indicator	Colour	Function
1 - 16 (16UIO) 1 - 8 (8UIO)	Green	State of associated universal input/output: unlit = OFF, fully lit = ON. Light intensity varies with output voltage when in analogue output mode.
1 - 16 (16DI)	Green	State of associated digital input: unlit = OFF, lit = ON.
1 - 8 (8DO)	Green	State of associated digital output: unlit = OFF (IN connected to NC), lit = ON (IN connected to NO).

**Service Button**

This is a multi-function button located on the front of the module and can be used to:

- assign an unaddressed module to a strategy module (or next available bus address if a strategy module does not exist),
- display the module's address by flashing the I/O bus indicator, or
- perform a module reset (in conjunction with a power cycle).

**Hand-Off-Auto (HOA) Control**

The 8DO-HOA module has a rotary/push-button control which allows the normal output operation (Auto Mode) to be manually overridden on each output. A back-lit LCD screen shows the current state of each output.

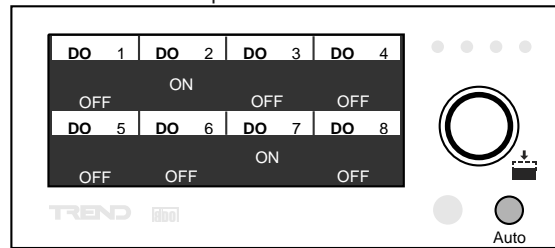

*Note: The language used for display text can be changed.*

While in Manual Mode, the rotary control can be used to select a particular output channel and change/override its current state.

Pressing the **Auto** button returns all outputs to Auto Mode where the outputs behave as follows:

Connected to Controller?	Strategy Defined?	8DO-HOA Output
Yes	Yes	set by strategy
Yes	No	OFF
No	–	OFF

**Important:** All outputs on a new (factory-set) module will power up in Auto Mode. The outputs of a previously used module will power up in whichever mode was selected when the module was powered down.

**Warning:** Manual operation of the HOA module does not provide a safe environment for working on electrical equipment, and must not be used as a substitute for appropriate lockout/tagout procedures during maintenance operations.

**Labelling**

XXXXXXXXXXXXXXXXXXXXXXXXXX

**FIRMWARE**

The firmware in each IQ5-IO Modules controls its basic functionality.

New versions of firmware may be made available from time to time to change or add functionality or to provide support for new products.

New firmware will be installed as part of an upgrade to the IQ5 controller. Once the controller has been upgraded it will automatically update the firmware of any attached I/O modules using the T1L IO bus.



## FIELD MAINTENANCE

The IQ5-IO Expansion Modules require no routine maintenance.



**WARNING:** Contains no serviceable parts. Do not attempt to open the unit. Failure to comply may cause damage to the unit.

---

## DISPOSAL

COSHH (Control of Substances Hazardous to Health - UK Government Regulations 2002) ASSESSMENT FOR DISPOSAL OF IQ5-IO Expansion Modules.

### RECYCLING

All plastic and metal parts are recyclable. The printed circuit board may be sent to any PCB recovery contractor to recover some of the components for any metals such as gold and silver.



### WEEE Directive:

At the end of their useful life the packaging, and product, and battery (if fitted) should be disposed of by a suitable recycling centre.

Do not dispose of with normal household waste.  
Do not burn.

---

## COMPATIBILITY

**Controllers:** IQ5.

---

## INSTALLATION

The IQ5-IO Expansion Modules are designed to be clipped on to a standard TS35 DIN rail or be screwed directly to a flat surface. They must be installed inside an enclosure rated to at least IP20 (or equivalent) or mounted outside normal reach (e.g. in a plenum). The modules are UL rated as 'UL60730 listed open energy management equipment'. The installation procedure involves:

- Mounting the I/O module(s) in position
- Connecting the I/O bus to remote modules (if required)
- Connecting additional PSUs (if required)
- Connecting universal inputs/outputs (UIO modules only)
- Connecting digital inputs (DI modules only)
- Connecting relay outputs (DO modules only)

- Isolating all I/O connections
- Downloading strategy to controller
- Reconnecting all inputs and checking operation
- Reconnecting all outputs and checking operation

A full description of installing the IQ5-IO modules is given in the IQ5-IO Modules Installation Instructions - Mounting (TG201484) and IQ5-IO Expansion Modules Installation Instructions - Configuring (TG201485).

**ORDER CODES**

<b>IQ5-IO-16UIO</b>	IQ5 I/O Module with 16 universal input/output channels
<b>IQ5-IO-8UIO-105</b>	IQ5 I/O Module with 8 universal input/output channels (105mm wide enclosure)
<b>IQ5-IO-16DI</b>	IQ5 I/O Module with 16 digital input channels
<b>IQ5-IO-8DO</b>	IQ5 I/O Module with 8 digital/relay output channels
<b>IQ5-IO-8DO-HOA</b>	IQ5 I/O Module with 8 digital/relay output channels with LCD and hand-off-auto controls
<b>IQ5-IO-16UIO-B</b>	IQ5 I/O Module with 16 universal input/output channels with BLE for local commissioning
<b>IQ5-IO-16DI-B</b>	IQ5 I/O Module with 16 digital input channels with BLE for local commissioning
<b>IQ5-IO-8DO-B</b>	IQ5 I/O Module with 8 digital/relay output channels with BLE for local commissioning
<b>IQ5-IO-8DO-HOA-B</b>	IQ5 I/O Module with 8 digital/relay output channels with LCD with hand-off-auto controls and BLE for local commissioning

**ACCESSORIES**

<b>IQ5-IO-ADPT-2</b>	Pack of 2 <b>IQ5-IO-ADPT</b> bus wiring adapters (for IQ5 controller and IQ5/IO modules)
<b>IQ5-IO-END-10</b>	Pack of 10 spare end covers (for IQ5 controller and IQ5/IO modules)
<b>IQ5-TCVR-105-10</b>	Pack of 10 spare 105mm terminal covers (for 105 mm IQ5/IO modules)
<b>DIN-CLIP-10</b>	Spare DIN Clip (pack of 10)
<b>AUX-TRM-16-10</b>	Auxiliary Terminal Block <b>AUX-TRM-16</b> (pack of 10)
<b>IO-JUMPER-4-10</b>	4 Pin Relay Output Jumper (pack of 10)
<b>SCRW-TB-2-PUR-50</b>	Spare 2-way Screw Terminal Plug Purple (pack of 50)
<b>SCRW-TB-2-YEL-50</b>	Spare 2-way Screw Terminal Plug Yellow (pack of 50)
<b>SCRW-TB-3-ORN-50</b>	Spare 3-way Screw Terminal Plug Orange (pack of 50)
<b>PUSH-TB-2-PUR-50</b>	Spare 2-way Push-fit Terminal Plug Purple (pack of 50)
<b>PUSH-TB-2-YEL-50</b>	Spare 2-way Push-fit Terminal Plug Yellow (pack of 50)
<b>PUSH-TB-3-ORN-50</b>	Spare 3-way Push-fit Terminal Plug Orange (pack of 50)

**RADIO FREQUENCY STATEMENTS AND REQUIREMENTS**

Frequency Band	
BLE	2400 MHz - 2483.5MHz
Maximum RF Power (in above range)	
CE BLE	10dBm (E.I.R.P)

Operation is subject to the following two conditions:  
 (1) this device may not cause harmful interference,  
 and (2) this device must accept any interference received, including interference that may cause undesired operation.

- This device complies with Part 15 of the FCC Rules.

- Important: Changes or modifications to this unit not expressly approved by the party responsible for compliance could void the user's authority to operate the equipment.

Note: This equipment has been tested and found to comply with the limits for a Class B digital device, pursuant to part 15 of the FCC Rules. These limits are designed to provide reasonable protection against harmful interference in a residential installation.

This equipment generates, uses and can radiate radio frequency energy and, if not installed and used in accordance with the instructions, may cause harmful interference to radio communications. However, there is no guarantee that interference will not occur in a particular installation.

If this equipment does cause harmful interference to radio or television reception, which can be determined by turning the equipment off and on, the user is encouraged to try to correct the interference by one or more of the following measures:

- Reorient or relocate the receiving antenna;
- Increase the separation between the equipment and receiver;
- Connect the equipment into an outlet on a circuit different from that to which the receiver is connected;
- Consult the dealer or an experienced radio/TV technician for help.

This device complies with Industry Canada license-exempt RSS standard(s).

Operation is subject to the following two conditions: (1) this device may not cause interference, and (2) this device must accept any interference, including interference that may cause undesired operation of the device.

*Le présent appareil est conforme aux CNR d'Industrie Canada applicables aux appareils radio exempts de licence. L'exploitation est autorisée aux deux conditions suivantes : (1) l'appareil ne doit pas produire de brouillage, et (2) l'utilisateur de l'appareil doit accepter tout brouillage radioélectrique subi, même si le brouillage est susceptible d'en compromettre le fonctionnement.*

## SPECIFICATION

### ELECTRICAL

Supply Voltage 24 Vac/dc ±20%, derived from T1L bus on IQ5 controller or optional external isolated output power source.

Supply Current dependant on module type and input/output usage (see page 6).  
Maximum current flow through module on I/O bus = 1 A.

I/O Bus  
Max. cable length 300 m (1000 ft) between modules. Max. modules 254.

### Inputs/Outputs

#### Universal Input/Output (UIO)

Function Measuring voltage, current, thermistor or digital input, or provide analogue control output (function set by strategy).  
Input Noise Rejection Minimum 60 dB series mode rejection

at input power supply frequency.

Analogue Resolution	16 bit (65,536 steps)
Input modes	16 bit (65,536 steps)
Output modes	13 bit (5019 steps)
Voltage Input	
Input range	0 to 10 Vdc, 2 to 10 Vdc.
Input resistance	9.4 kΩ.
Accuracy Current	±0.5% of span (50 mV).
Input	
Input range	0 to 10 mA, 4 to 10 mA, 0 to 20 mA, 4 to 20 mA.
Current source	onboard 24Vdc or external PSU.
Input resistance	120 Ω.
Accuracy	±0.5% of span (100 μA).
Thermistor Input	
Temperature (NTC)	10 kΩ @ 25°C (77°F))
Input range	-40 to 110°C (-40°F to 230°F)
Accuracy	±0.3°C (-20°C to 90°C (-4°F to 194°F)); ±0.4°C (<-20°C (-4°F) or >90°C (194°F))
Resistance	
Input range	0 to 300 kΩ
Accuracy	1% of measured value or 10 Ω, whichever is the greater
Bridge resistor	12.2 kΩ.
Bridge supply	3.3 V.
Digital Input	
Input voltage	0 to 10 Vdc (40 Vdc maximum).
ON state	<2 Vdc @ 3.5 mA (sink).
OFF state	>4 Vdc (or open circuit).
Pulse rate	100 Hz max. (min. duty cycle 50% / 50% = 5 ms ON / 5 ms OFF).
Analogue Output	
Voltage range	0 to 11 Vdc, 0 to 10 Vdc, 1 to 10 Vdc, 2 to 10 Vdc.
Current	0 to 20 mA, 4 to 20 mA.
Accuracy	±0.5% of span (50 mV).
Digital Inputs (DI)	
Function	On/off state (or pulse count) to strategy from volt free contact, logic circuit (e.g. TTL, CMOS), open collector (transistor) or open drain (FET), or 24 Vac input.
Input Voltage	0 to 10 Vdc (40 Vdc maximum).
ON state	<2 V @ 3.5 mA (sink).
OFF state	>4 V (or open circuit).
Pulse rate	100 Hz max. (min. duty cycle 50% / 50% = 5 ms ON / 5 ms OFF).

#### Digital/Relay Outputs (DO)

Function Single pole changeover control from strategy for general purpose use.

#### Contact Ratings (per channel):

Voltage Range	Channels 1-4, 6-9		Channel 5	
	Resistive	Inductive	Resistive	Inductive
19 to 250 Vac	5 A	3 A	10 A	6 A
12 to 29 Vdc*	5 A	3 A	10 A*	6 A*

\* for UL60730-1 compliance channel 5 must be derated to maximum 24 Vdc @ 5 A for NC switching.

## IQ5-IO

## Data Sheet

Maximum Total Load 12 A (across all channels)  
Maximum Inrush 7.5 A (channels 1-4, 6-9);  
15 A (channel 5).

Minimum Load 10 mA (all channels).  
Minimum Cable Size 1.5mm<sup>2</sup> (16 AWG).

*Note: To meet safety requirements, the relays in block 1 (ch.14) and block 2 (ch.5-8) must all be switching either low voltage or mains and not a mixture of voltages. If switching mains, they must all switch the same phase and polarity. Arc suppression circuit (RC) recommended for inductive loads (see TG200208). UL rating applies up to 240 Vac (120 VA) maximum.*

### CONTROLS

All variants  
Service Button Momentary action push-release.  
HOA variants  
Control Rotary/push-button.  
Display Backlit monochrome LCD panel.

### SPECIFICATION (continued)

#### MECHANICAL

Dimensions (overall WxHxD)  
105 mm modules 109.5 x 131 x 60 mm (4.31 x 5.16 x 2.36").  
HOA modules 109.5 x 131 x 67.5 mm (4.31 x 5.16 x 2.66").  
Material (enclosure) Flame Retardant Polycarbonate.  
Weight  
16UIO 0.344 kg (0.76 lb);  
8UIO 0.306 kg (0.68 lb);  
16DI 0.336 kg (0.74 lb);  
8DO 0.363 kg (0.80 lb);  
8DO-HOA 0.382 kg (0.84 lb).  
Mounting Options  
DIN Rail IEC/EN 60715 TH35x7.5 or TH35x15 (1.5 mm maximum thickness).  
Surface mount Two screw fixing.

#### Connectors

I/O Bus Integral spring contacts for inter-module connection. IQ5-IO-ADPT wiring adapter required for cable connection.  
Inputs/Outputs 2 part connectors (5 mm pitch) with rising cage clamp screw terminals.  
Cable size 0.14 to 2.5 mm<sup>2</sup> (22 to 12 AWG). For UL compliance the input power connections must be made using 18 AWG or larger wire rated at least 90°C (194°F).

#### ENVIRONMENTAL

This device is suitable for indoor use only.

#### Approvals and Certifications

- UL 60730-1, Standard for Automatic Electric Controls for Household and Similar Use, Part 1: General Requirements;
- UL 60730-2-9;
- CAN/CSA-E60730-1:13, Standard for Automatic Electrical Controls for Household and Similar Use, Part 1: General Requirements;

- CAN/CSA-E60730-2-9;
- CAN ICES-3 (B)/NMB-3(B)
- Complementary listing for UL916, CSA C22.2 No. 205;
- BTL-listed, BACnet AAC profile;
- SASO-approved;
- CE-approved;
- FCC part 15B and 15C
- RSS-247 Issue 2
- RSS-Gen Issue 5

#### Classification According to EN60730-1 and UL60730-1

Environmental conditions Equipment intended for use in industrial environments.  
Construction Independently mounted electronic control unit with fixed wiring; panelmounted on DIN rail.  
Action type 1.B.  
Rated impulse voltage 24 V circuits: 500 V;  
Relay outputs (DO): 2500 Vac.  
Pollution degree 2.  
Protection against shock Class 0 (without terminal covers);  
Class II (with terminal covers).  
Software class A.

#### Energy Performance of Buildings

EN ISO 52120-1 This controller, when used as part of a complete Trend Controls system AND when programmed with an appropriate application/strategy can support compliance with EN ISO 52120-1. This enables buildings to achieve up to 30% energy cost savings (Energy classification "A") alongside maximizing comfort and well being.  
EN12098-1 This control equipment complies with the performance specification defined in EN12098-1. With an appropriate application/strategy it can make use of operation modes, scheduling, optimum start/stop, outside air temperature and frost protection to enhance the energy performance of buildings.

#### Ambient Environmental Limits

Humidity 5 to 90%RH non-condensing.  
Temperature  
Storage -40 to +70°C (-40 to +158°F).  
Operating  
HOA modules -20 to +65.5°C (-4 to +150°F).  
All other items -40 to +65.5°C (-40 to +150°F).

*Note: For temperatures below 0°C (32°F) special care must be taken that there is no condensation on or within the unit.*

Altitude <4000 m (13124 ft).  
Pollution Degree 2 (only non-conducting pollution occurs).

Protection IP20 if mounted in an enclosure rated at IP20 or equivalent.

Please send any comments about this or any other Trend technical publication to [techpubs@trendcontrols.com](mailto:techpubs@trendcontrols.com)



© 2022 Honeywell Products and Solutions SARL, Connected Building Division. All rights reserved. Manufactured for and on behalf of the Connected Building Division of Honeywell Products and Solutions SARL, Z.A. La Pièce, 16, 1180 Rolle, Switzerland by its Authorized Representative, Trend Control Systems Limited.

Trend Control Systems Limited reserves the right to revise this publication from time to time and make changes to the content hereof without obligation to notify any person of such revisions or changes.

**Trend Control Systems Limited**

St. Mark's Court, North Street, Horsham, West Sussex, RH12 1BW, UK. Tel: +44 (0)1403 211888, [www.trendcontrols.com](http://www.trendcontrols.com)