







## BACnet Communications (../BAC variants only)

The IQ41x../BAC controller is designed to be a BACnet Application Specific Controller. BACnet is an open protocol that enables the products of a number of different manufacturers of building automation and control equipment to communicate with each other. It supports communication using BACnet over IP (Ethernet) including:

- Access to IQ41x parameters over BACnet,
- Alarm delivery,
- IC comms to a BACnet device.

A full specification of the objects, properties, and BIBBS (BACnet Interoperability Building Blocks) supported by the IQ41x Series Controllers are given in the IQ4 Protocol Implementation Conformance Statement (TP201248). The mapping of the BACnet properties to the Trend parameters is covered in the IQ4 Configuration Manual (TE201263).

## XML Web Services

The IQ41x includes XML web services. XML is a general purpose specification for creating custom markup languages. It helps developers create web pages and also provides a basic syntax that enables information to be shared by different computers and applications. The IQ41x XML syntax is described in the IQ4 Configuration Manual (TE200768).

## Networking

In order to connect to the Trend network the IQ41x will create its own internal LAN which includes the following nodes:

- a CNC for its own controller,
- a supervisor CNC (sCNC1) for its RS232 port,
- a supervisor CNC (sCNC2) for its USB port,
- a virtual CNC (vCNC), and
- a virtual INC (vINC).

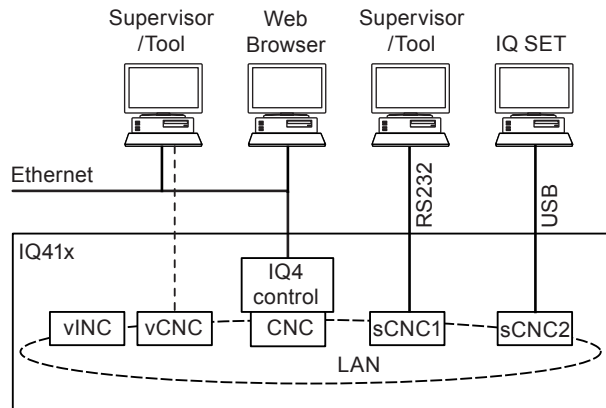

**Default CNC Addressing:** The IQ41x device (outstation) address is factory-set (in the Address module) as follows:

- Local LAN** set to 20;
- Local Address** set on a rolling basis in the range 11 to 119, so that in a batch of IQ41x controllers, each will have a different default address (printed on the unit's serial label).

**sCNC1 Functionality:** If the RS232 port address is set to 0 (default), sCNC1 is disabled and a connected device can only communicate with the IQ41x. If the address is configured to be non-zero, sCNC1 is enabled with that address on the LAN and allows a connected device to communicate with the entire Trend network.

**sCNC2 Functionality:** When a PC running IQ SET is connected to the USB port it uses sCNC2. If the USB port address is set to 0 (default), sCNC2 is dynamically created at address 125 for the duration of the IQ SET session. When the PC is removed sCNC2 times out and no longer exists on the network. If the address is configured to be non-zero, sCNC2 remains on the network at all times.

**vCNC Functionality:** Allows a supervisor tool/display to make a permanent connection to the Trend network using TCP/IP. By default the vCNC is disabled.

**vINC Functionality:** When the IQ41x joins a LAN on Ethernet, the controller with the lowest IP address assumes INC functionality (using its vINC at address 126); any vINCs in other controllers on that LAN will automatically be disabled. The vINC does not exist on a current loop LAN.

**IC Comms:** The IQ41x can communicate with other IQ controllers and BACnet devices (../BAC variants only) using IC Comms. Some controllers running earlier versions of firmware may not support all IC Comms types. See 'Compatibility' on page 12.



**HARDWARE**

**Inputs and Outputs**

The I/O channels available vary with the IQ41x type as shown in the table below:

		IQ411/24VAC	IQ411/230	IQ412/24VAC	IQ412/230	
Inputs	Universal	3	3	3	3	
	Digital	2	2	2	2	
Outputs	Solid State Digital	24 Vac	6	0	4	0
		24 Vac Synthesised	0	6	0	4
	Analogue	0	0	2	2	
	Auxiliary Supply	1	1	1	1	

Screened cable is not generally required unless the cable passes through electrically noisy environments. Where it is used the screen must be connected to the local panel/enclosure ground and left unterminated at the far end.

**Universal Inputs (IN1 to IN3)**

Each input channel will function as one of the following:

- thermistor input,
- voltage input,
- digital input, or
- current input.

The input function is set automatically by the IQ41x strategy.

**Thermistor input:** Used for a thermistor (NTC 10 kΩ @ 25°C (77°F), -40 to 110°C (-40°F to 230°F)), potentiometer (0 to 200 kΩ) or fan speed control. The thermistor bridge resistor is 12 kΩ with a bridge supply 3.3 V.

Example wiring

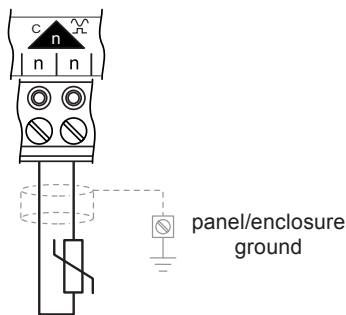

**Voltage input:** Used with a 0 to 10 Vdc source.

Example wiring

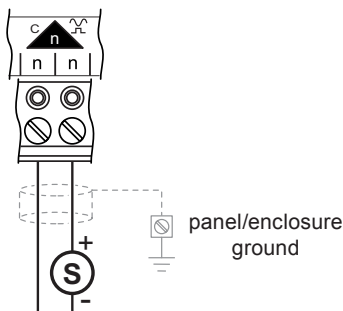

**Digital input:** Used for a volt free contact, logic circuit (e.g. TTL, CMOS), open collector (transistor) or open drain (FET).

Example wiring

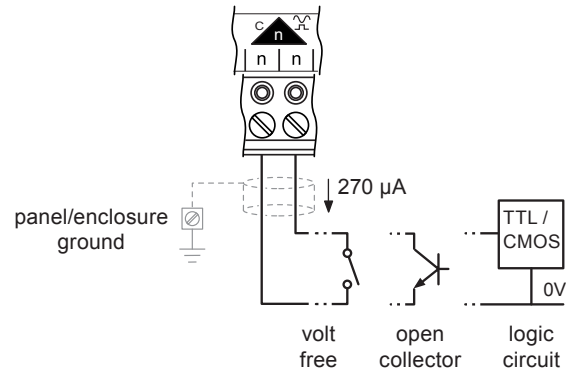

The volt free contact has a nominal wetting current of 270 µA. The input is ON when the contact is closed.

An open collector or open drain must be able to sink 270 µA. The input is ON when the transistor or FET conducts. Correct polarity must be observed.

A logic circuit must be able to sink 270 µA. The input will be ON when the voltage present on the input terminal is less than 2 Vdc (minimum 0 V). A voltage greater than 3.5 Vdc (maximum 50 Vdc) or open circuit will turn the input OFF. Voltage levels between 2 and 3.5 Vdc may cause indeterminate operation.

**Current input:** Used for 0 to 20 mA sources which can be externally powered or loop powered (from the Auxiliary Supply Output, i.e. terminal 12).

Example wiring

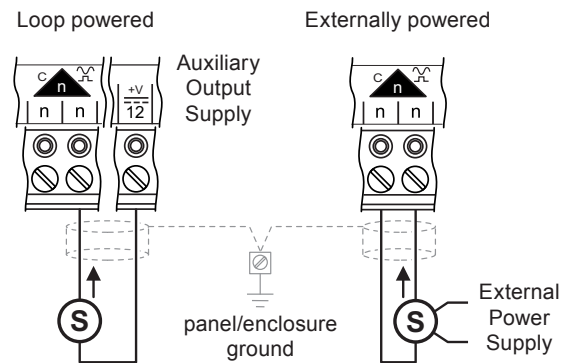



**Digital Inputs (IN4, IN5)**

Used for a volt free contact, logic circuit (e.g. TTL, CMOS), open collector (transistor) or open drain (FET).

Example wiring

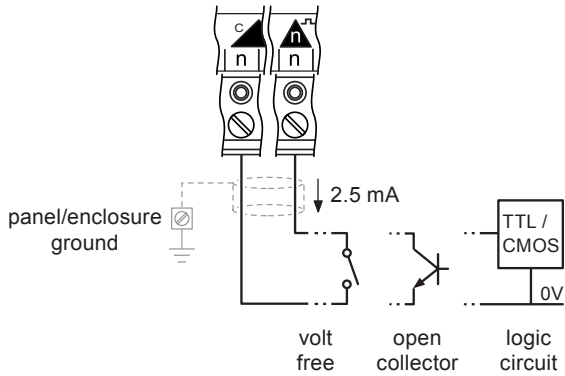

The volt free contact has a nominal wetting current of 2.5 mA. The input is ON when the contact is closed. There is no polarity.

An open collector or open drain must be able to sink 2.5 mA. When the transistor or FET conducts, the digital input will be ON. Correct polarity must be observed.

**Digital Outputs (IQ411: OUT6, OUT11; IQ412: OUT8 to OUT11)**

These solid state outputs are suitable for use with 24 Vac thermal type actuators, 24 Vac synchronous motors, and 24 Vac relays. The outputs on /24VAC and /230 versions are equivalent, the only difference is the power on the common terminal.

**IQ41x/24VAC:** Switches 24 Vac, 500 mA maximum for a channel, 500 mA maximum shared between all channels (4 on IQ412 or 6 on IQ411). Terminals and example wiring:

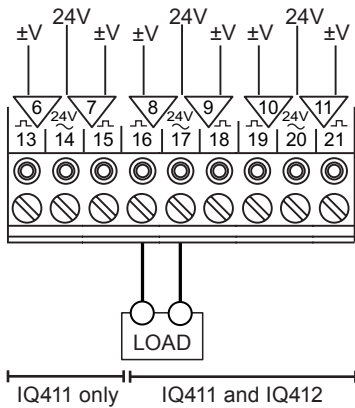

**IQ41x/230:** Switches 24 Vac (synthesised), 300 mA maximum for a channel, 300 mA maximum shared between all (4 or 6) channels. Terminals and example wiring:

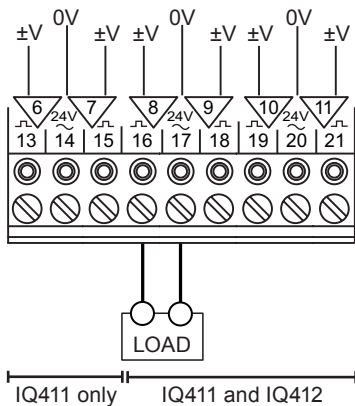

Each output provides an independent 24 Vac feed for driving 24 Vac loads, such as thermoelectric (thermic) actuators, and raise lower actuators, (e.g. the Trend range of thermic actuators).

The electrical characteristic of this output is approximately as shown below. Loads should be assessed against this before they are used with IQ41x/230.

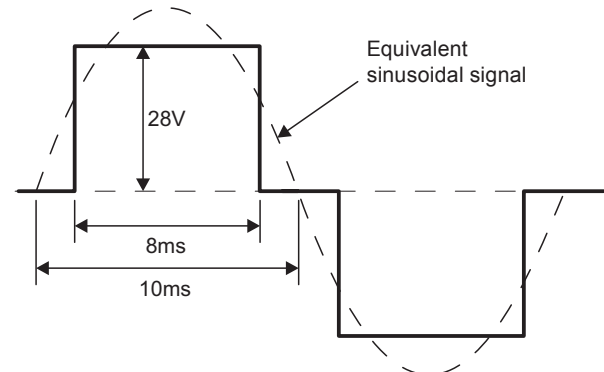

*Note: 24 Vac is not available from the IQ41x/230. Certain types of actuator which require a direct 24 Vac supply (e.g. spring return) cannot be powered from the IQ41x/230, and will require a separate 24 Vac supply.*

**Analogue Outputs (IQ412 only: OUT6, OUT7)**

These provide a variable control voltage between 0 and 10 Vdc. The output can source up to 20 mA (see "Combined Supply") and sink up to 3 mA.

If screened cable is used the screen must be connected to the panel/enclosure ground and unterminated at far end.

Example wiring

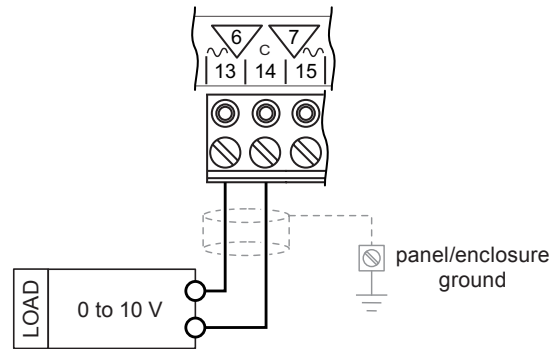

**Auxiliary Supply Output**

This output can be used to supply I/O devices (e.g. sensors). It provides 20 Vdc ±10% from terminal 12 with a return through any 'C' terminal.

A maximum current of 90 mA is available.



**Combined Supply**

The IQ41x combined supply provides power for the:

- Analogue outputs (IQ412 only),
- Auxiliary supply terminals,
- Wallbus, and
- RS232 port.

On **/24VAC** variants a maximum combined supply current of 120 mA is available. If the total power requirement of the combined supply exceeds this limit it will be necessary to power some of the items using external power sources.

*Note: For further details on calculating the available current from the combined supply, see the IQ4 Configuration Manual (TE201263).*

On **/230** variants the combined supply can fulfil all power requirements up to the maximum values specified on page 15.

**Enclosure**

The IQ41x is housed in a polycarbonate case. Integral spring clips on the back of the case enable the unit to be clipped on to (and quickly released from) a standard TS35 DIN rail.

The **/230** version must be installed in a secondary enclosure with a minimum protective rating of IP20 (or equivalent).

The **/24VAC** version must be installed in a secondary enclosure with a minimum protective rating of IP20 (or equivalent) or mounted outside normal reach (e.g. in a plenum).

The unit may be mounted horizontally or vertically but not upside down or on its back:

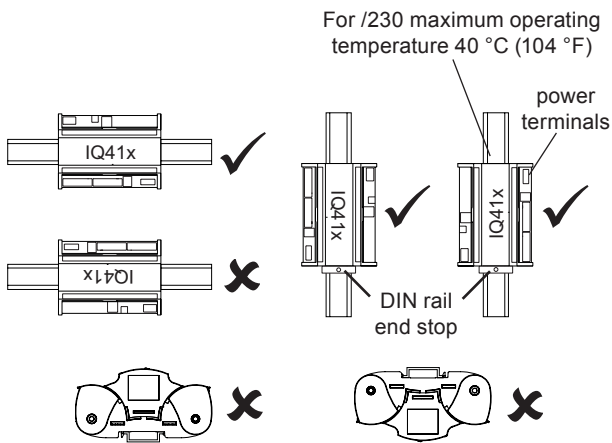

Rotating clear polycarbonate covers provide access for the power, communications and I/O connections.

The IQ41x has both 230 Vac and 24 Vac input power options.

**/230:** This option requires 230 Vac  $\pm 10\%$ , 50/60 Hz. The IQ41x input power earth (ground) terminal is isolated from the input power neutral, and must be separately earthed (grounded) locally; this ground terminal is internally connected to the IQ41x electronics earth (ground).

The 230 V supply must include a dedicated 5 A fuse complying with IEC60269 (BS1362) and a suitably rated switch in close proximity and be clearly marked as the disconnecting device for the unit. A 5 A circuit breaker with high breaking capacity may be used as an alternative.

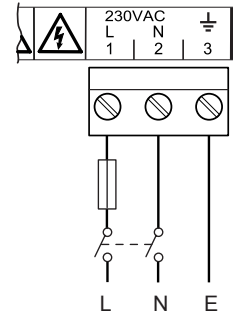

**/24VAC:** This option requires 24 Vac  $\pm 10\%$ , 50/60 Hz. It uses an half wave rectifier internal power supply unit. Multiple controllers with half wave power supplies may be powered from a single grounded transformer but the supply polarity must be maintained across all units supplied from the same transformer.

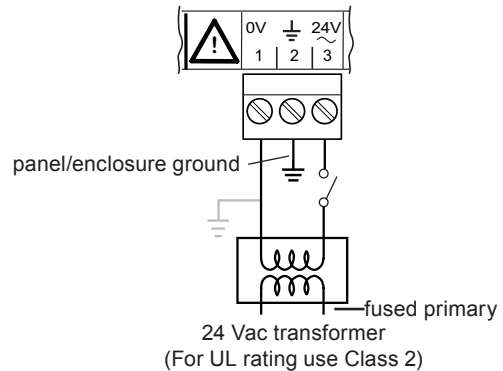

The local earth terminal (2) must be earthed (grounded) at the controller. If one side of the transformer secondary is earthed, then this **MUST** be connected to the controller's 0 V terminal (1). For UL rating the input power connections must be made using 18 AWG or larger wire rated at least 90°C (194°F). The 24 V supply must include a suitably rated switch in close proximity and be clearly marked as the disconnecting device for the unit. Do not position the equipment so that the disconnecting device is difficult to operate.

**Service Button**

Can be used to generate a network message which identifies the IQ41x by means of its unique serial number to system tools, e.g. to find the controller's device address and LAN number.

It can also be used to reset the IQ41x to factory defaults; for further details see the IQ4 Configuration Manual (TE201263).



## Indicators

Various indicators are provided giving feedback on the operational status of the controller.

**General** (in centre of cover):

Indicator	Colour	Function
Power	Green	Condition of input power supply
Watchdog	Red	Presence of a firmware/strategy fault
LAN OK	Green	Status of the Trend LAN (operational on /LAN variants only)
Service	Yellow	Service button activated. Flashes if a powered device is connected to the USB port when IQ41x is <i>not</i> powered.

**Current Loop** (adjacent to current loop connector - operational on /LAN variants only):

Indicator	Colour	Function
RX	Yellow	Status of link from upstream device
TX	Yellow	Status of link to downstream device

**Ethernet** (on end of Ethernet connector):

Indicator	Colour	Function
OK	Green	Status of connection (Ethernet LINK)
RX	Yellow	Presence of data reception

The data (firmware, strategy, parameters) is stored in flash memory which is non-volatile in the case of power failure. Changes to the Address module are stored immediately. Other changes are generally stored around midnight, in addition structural changes (e.g. module interconnections) are stored 15 s after the last change, and critical data changes (e.g. strategy values), are stored on power failure or other similar fault conditions. The tools (e.g. IQ SET) will send an archive instruction after parameter changes causing immediate storage of changes.

A supercap is used to maintain the real time clock (time and date). In the event of power failure this will support the clock for 8 days (typically).

*Note: Operation at elevated temperature or high humidity levels will reduce the lifetime of the supercap. Extended operation in these conditions may permanently reduce the capacity of this component and result in a reduction in the number of days that the controller can successfully backup the time and date.*

## Labels

A small two part label is attached to the unit which displays the unit's serial number and MAC address (in both text and barcode format). Space is provided on the label for recording the unit's device (outstation) address, LAN number and IP address (if DHCP is not being used). It has a tear-off self-adhesive label strip that also contains the serial number and MAC address (text and barcode) which can be adhered to a paper record, e.g. a building plan or log book.

A second large adhesive label is also supplied which contains the unit's serial number in text and barcode formats. This is intended to be mounted on the outside of the equipment cabinet or enclosure containing the IQ41x Series Controllers. If the unit is located in a difficult-to-reach location, this label can be scanned from a distance using a suitable barcode scanner.

The barcodes on both labels conform to the 'code 128 auto' format.





Replacing IQ21x & IQ7x with IQ41x

The IQ41x has design features which enable it to replace or extend systems which include old IQ21x and IQ7x controllers.

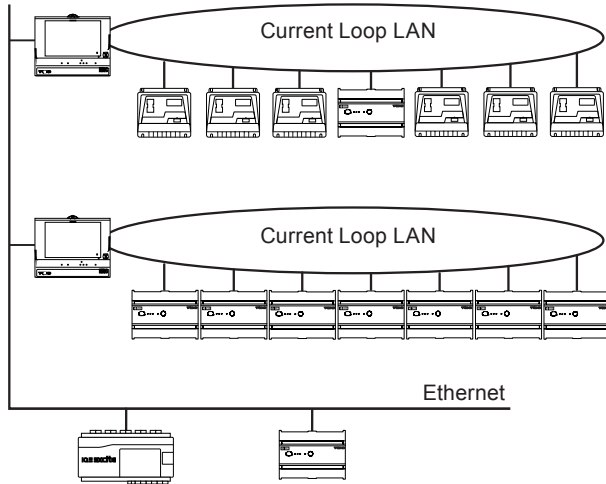

The diagram above shows IQ41x/LAN replacing/extending an IQ21x system on the Trend current loop LANs, and an IQ41x connected to a Trend Ethernet LAN.

The IQ41x is a of a similar size to the IQ21x and has the same I/O terminal allocation. The IQ41x Adaptor Plate accessory has the same mounting points as the IQ21x controller and provides DIN rail clips for the IQ41x. These IQ41x features along with the adaptor plate facilitate its use as an IQ21x replacement. It is supplied with a screw fixing cable tie to be used as the supply cable restraint.

The I/O terminals can be unplugged from the IQ21x and plugged into the IQ41x terminal position. It is the same for the input power terminals except they need to be twisted through 180°. The LAN cable extender enables the LAN connections to be made by the side of the IQ41x unit. The LAN connector holder plastic on the mounting plate may be snapped off and mounted in a more convenient position (with single 5 mm screw fixing).

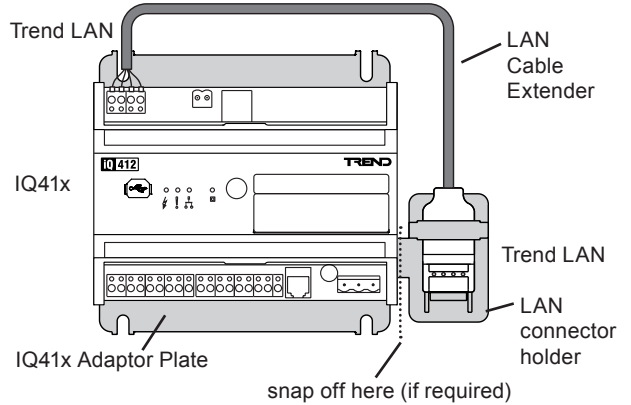

The IQ41x may also be used as replacement for the IQ7x series controllers. The I/O connections are reasonably compatible except for the IQ78. The input terminals can be unplugged from the IQ7x and plugged into the IQ41x terminal position, and the same with the output terminals for the IQ71 although IQ72, 73 will need the wiring to cross-connected. The 24 Vac supply connector will need to be changed. The IQ41x Adaptor Plate accessory mounting points are slightly different to the IQ7x's, and but the slots are elongated to take either. The LAN cable extender must be used in the same way as for the IQ21x, enabling the LAN terminals to be unplugged from the IQ7x and plugged into the IQ41x terminal position.

**IQ41x Adaptor Plate**

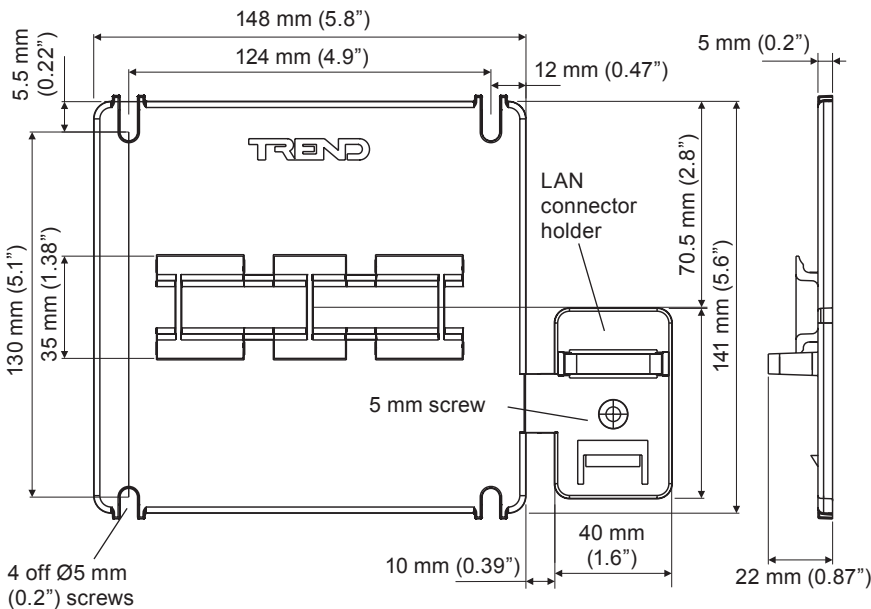

**LAN Cable Extender**

Length: 450 mm (17.72")

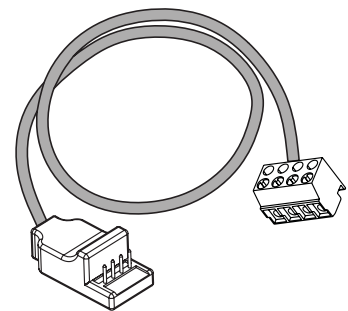



## FIRMWARE

The firmware in the IQ41x controls its basic functionality and provides a range of modules that can be configured to produce a control strategy.

### Modules

The range of modules provided in the IQ41x firmware are listed in the table below. Full details of each module can be found in the IQ4 Configuration Manual (TE201263).

Module	brIQs	Max. number of Modules	Note
Address	24	1 (fixed)	③
Alarm Destination	14	(8)	
Alarm Group	9	500	
Alarm Route	9	500	
Alarm Log	0	1 (fixed)	③
Analog Node	16	510	
Digital Byte	16	1012	
Digital Input	28	1500	①
Directory	13	500	
Display	19	1500	
Driver	57	500	①
Function	19	1000	①
IC Comms	19	1000	①
Interface	130	500	①④
Knob	13	1500	
Logic	19	1000	①
Loop	55	500	
Network	0		③
NTD	30	limited by max. brIQs only	
Option	0		③
OSS	34	500	
Page	4	500	
Plot	12	500	
Program	0	1 (fixed)	③
Schedule Offset	21	500	
Sensor	76	1500	①
Sensor type	12	99	
Sequence	106	1 (fixed) (300 steps)	
Switch	10	1500	
Time	38	1 (fixed)	
Time Schedule	566	100	②
User	12	500	
Virtual CNC	9	1	③

#### Notes:

- ① The number of brIQs used on these modules varies with the module type. The largest size is shown here.
- ② Includes a maximum of 50 exceptions per module.
- ③ These modules are always present in the IQ41x.
- ④ Additional 5 brIQs required per input and output.

The quantity of each type of module may be adjusted to match the requirements of the application subject to the following:

- A maximum of 4000 modules in total,
- A maximum for each type of module, and
- The IQ41x memory capacity (10,000 'brIQs').

The maximum number of modules for each type, and the number of brIQs required per module are shown in the table above.

### Plot Modules

The IQ41x Plot modules can plot any connectable module output (analogue or digital). There are four types of Plot module: Synchronised, Triggered, Periodic and COV (change of value). Although all four types are BACnet interoperable, only periodic plots can be compliant with the BACnet standard. All Plot modules can generate a buffer ready alarm when the number of records equals a notification threshold.

The maximum number of records per plot is 1000. The maximum total number of records (for all plots) depends on the available plot memory (measured in log points) and the type of plots used - each Synchronised plot record requires 5 log points, while each Triggered, COV or Periodic plot record requires 10 log points:

maximum plot memory (log points)	max. number of records	
	synchronised plots	triggered, COV or periodic plots
1,000,000	200,000	100,000

*Note: A maximum of 100 plots can be serviced in a 1 s period (e.g. 100 x 1 s plots only). This is calculated on the average plots serviced in 1 s, so a 1 minute plot would contribute a 1/60. For example 90 x 1 s plots plus 360 x 1 min would give 96 (90+6) plots per second on average. The periodic and triggered plots must also be counted and it's up to the engineer to make his best estimate.*

### Firmware Upgrades

New versions of firmware may be made available from time to time to change or add functionality or to provide support for new products.

Firmware can be upgraded using a PC running the IQTool Firmware Upgrade Applet, and to the IQ41x connected over Ethernet (recommended for speed) or the Trend current loop.



**Timemaster**

The IQ41x can act as a system Timemaster to synchronise the time and date across the Trend system. It can use SNTP (simple network time protocol) to obtain precision current time from an unauthenticated NTP server on the Internet. Daylight saving can be implemented automatically (via timezone setting) or manually by specified dates and time adjustment.

The web interface does not allow the strategy structure to be modified (e.g. changing module interconnections, adding or deleting modules).

**Alarms**

The IQ41x will generate Network, General, and Item alarms. Network alarms are generated by the Trend Network nodes, General alarms are generated when the IQ41x detects a problem within its own hardware or program, and Item alarms are generated by the strategy, and are normally due to a faulty plant condition.

Graphical display pages (GraphIQs), which are configured using the IQ41x display and directory modules, can also be accessed.

Network alarms are sent to supervisors or tools connected to the RS232 local supervisor port, USB local engineering port, or to the controller's vCNC.

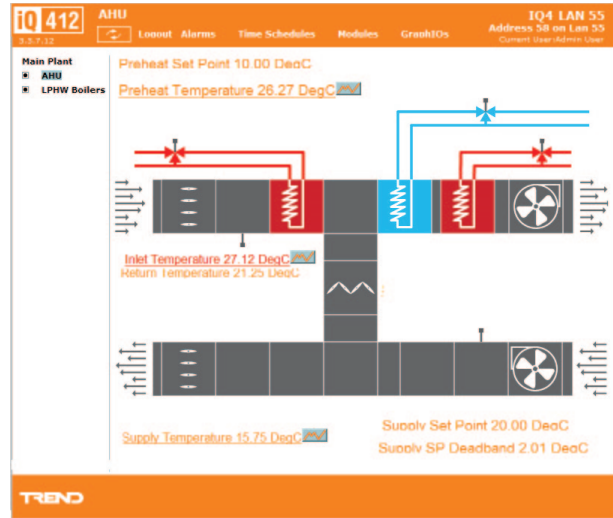

General and Item alarms can be sent either to a designated Trend LAN address, to an IP address, or as an email. Alternatively, certain Item alarms (sensor, digital input, digital driver readback, and plot), can be sent to a BACnet device.

Alarms sent to a Trend LAN address, or to an IP address can either be sent in text, coded, or attribute format. Network alarms are sent in text format only.

For further details of web pages see the IQ4 Configuration Manual (TA201263), the IQ4 Web User Guide (TC201256), and the Graphical Display Pages Editor Manual (TE200629).

For coded alarms the protocol limits the item number to 255 maximum. For text alarms the maximum item label length is 20 characters (although the 963 can be set up to use labels previously learnt).

**Language**

Sending an alarm by email requires the Email Server Address to be set up in the address module. The Email Server Address can be an IP address, an internet domain name, or a host name; the internet domain name or host name require a DNS server address or a WINS server address respectively to be set up in the network module so that the name can be resolved.

The user can specify which language the IQ41x uses for the display of web pages and for transmitted alarms. The standard languages are in the controller as supplied. In the controller the Address module has a language parameter which will be set to the default language, but can be changed to any one of the other available languages. The IQ41x can use languages which require 8 bit code (i.e. special or accented characters) and can also operate with right to left languages (e.g. Chinese, Arabic).

All alarms (except Network alarms) are also stored locally in the Alarm Log. The alarm log can record up to 300 alarms. Once this limit is reached each new alarm will overwrite the oldest record.

**Identification**

**Web Server**

The IQ41x will identify itself as an IQ4 to w comms.

Information from the IQ4 can be viewed or adjusted from a web client (PC, tablet or smartphone) over any TCP/IP network (e.g. company intranets) using secure HTTPS protocol. All that is required is the IP address or host name of the, and a user name and password. Once connection to the controller has been made, it is possible to view/adjust occupation times, view the alarm log, and view/adjust/graph individual module parameters.

**STRATEGY**

**IQ 412 Driver Overview**

Address Page  
Alarm Destinations  
Alarm Groups  
Alarm Routes  
Analogue Nodes  
Digital Bytes  
Digital Inputs  
Directories  
Displays  
**Drivers**  
Functions  
IC Comms  
Interface Modules  
IO Modules  
Knobs  
Logics  
Loops  
Networks  
Non-Trend Devices  
Options  
OSS  
Performance  
Plots  
Program  
Schedule Offsets  
Sensors  
Sensor Types  
Sequence Table  
Switches  
Time  
Time Schedules  
Users  
Virtual CNCs

Item	Label	Value	Module Status	Alarm
D1	Driver 1	0.00	Normal	No Alarm
D2	Driver 2	0.00	Normal	No Alarm
D3	Driver 1	0.00	Normal	No Alarm
D4	Driver 2	0.00	Normal	No Alarm
D5	Driver 5	0.00	Normal	No Alarm
D6	Driver 6	0.00	Normal	No Alarm
D8	Driver 12	0.00	Normal	No Alarm
D11	AO1 channel 1	0.00	Normal	No Alarm
D13	AO1 channel 1	0.00	Normal	No Alarm
D14	AO1 Channel 4	0.00	Normal	No Alarm
D15	AO1 channel 5	0.00	Normal	No Alarm
D16	AO1 Channel 6	0.00	Normal	No Alarm
D17	AO1 channel 7	0.00	Normal	No Alarm
D18	AO1 Channel 8	0.00	Normal	No Alarm
D20	DO1 Channel 2	0.00	Normal	No Alarm
D21	DO1 channel 1	0.00	Normal	No Alarm

Get From

In order to operate as a controller, the modules provided by the firmware must be configured to define the way the controller is to control the connected equipment. This configuration is known as the strategy. Strategies are configured using the System Engineering Tool (IQ SET).

This produces a strategy file (*filename.IQ4*) that can be downloaded to the controller to define its operation. This file consists of all the strategy module instances, their parameters, and links. When this is downloaded it is stored in the controller and then run using the controller firmware.

For details of using IQ SET see the System Engineering Tool Manual (TE200147).

## FIELD MAINTENANCE



The IQ41x Series Controllers require no routine maintenance.



**WARNING:** Contains no serviceable parts. Do not attempt to open the unit. Failure to comply may cause damage to the unit.

## DISPOSAL

COSHH (Control of Substances Hazardous to Health - UK Government Regulations 2002) ASSESSMENT FOR DISPOSAL OF IQ41x Series Controllers.

### RECYCLING

All plastic and metal parts are recyclable. The printed circuit board may be sent to any PCB recovery contractor to recover some of the components for any metals such as gold and silver.



### WEEE Directive:

At the end of their useful life the packaging, and product should be disposed of by a suitable recycling centre.

Do not dispose of with normal household waste.  
Do not burn.

## COMPATIBILITY

**Browsers:** This device has been successfully tested with Internet Explorer (v10 & 11), Chrome (v29.0.1547.0), Mozilla Firefox (v23), Safari (v5.1.7) and with the default browser on the following device operating systems:

Apple iOS 8.1.3  
Android 5.0 'Lollipop'  
Windows Phone 8.1

It should work with all modern browsers, smart phones, and tablets (with JavaScript enabled) available at the date of release of this product.

Owing to the rapidly changing nature of web devices, new devices and browsers will become available after the release of this product. If you would like to check the compatibility of IQ4 with your device, please connect to: [iq4demo.trendcontrols.com](http://iq4demo.trendcontrols.com). Log in with username: mobile and password: trend.

**Supervisors and displays:** 963 v3.5 or greater, 916, IQView, IQView4, IQView8, RD-IQ, SDU-xcite.

*Note: The NDP is not compatible with IQ41x; it will not recognise an IQ41x connected to its network.*

**Wallbus:** RD-WMB, RS-WMB, RV-WMB.

**Utility software:** IQ SET v7.05 or greater.

**IC Comms:** IQ4, IQ3, IQ2, IQeco, IQL, and IQ1 (v3 onwards).

*Note: Some controllers running earlier versions of firmware may not support all IC Comms types. Refer to the IQ4 Configuration Manual (TE201263) for full compatibility details. For details on using IC Comms with IQL controllers refer to the Trend LonWorks Products Engineering Manual (TE200292).*

**Controllers:** IQ3/IQ4 directly and IQ1, IQ2, IQL by way of XTEND. IQ41x/LAN communicates with IQ2, IQ1 directly. IQeco by way of IQ4NC.

**Strategies:** IQ1, IQ2, IQ3 can be imported into IQ SET, converted into IQ4 strategies, and then downloaded into an IQ41x. If the strategy file accesses I/O channels beyond those available in the IQ41x the strategy will be rejected.

**Ethernet Nodes:** XTEND, NXIP, or EINC.

*Note: NXIP or EINC must not be used in an automatic IP addressing (DHCP) environment.*

**BACnet Devices:** (/BAC variants only). The IQ41x controller is certified as a BACnet Application Specific Controller (B-ASC), for details of the certification go to:

<http://www.bacnetinternational.net/btl/index.php?m=52>.

Compatibility is defined in IQ4 Product Implementation Conformance Statement (TP201248).

## INSTALLATION



The IQ41x is designed to be clipped on to a standard TS35 DIN rail. The /230 version must be installed in a secondary enclosure with a minimum protective rating of IP20 (or equivalent). The /24VAC version should be installed in an enclosure or outside normal reach (e.g. in a plenum). All /24VAC controllers are UL rated as 'UL916, listed open energy management equipment'.

The installation procedure involves:

- |  |  |
|--|--|
| Mounting the controller in position            | Setting up LAN number and Device address               |
| Connecting power                               | Checking network                                       |
| Connecting Ethernet (if required)              | Configuring the strategy                               |
| Connecting RS232 (if required)                 | Testing strategy using controller simulation in IQ SET |
| Connecting Current Loop (../LAN only)          | Downloading strategy and other configuration files     |
| Connecting the I/O channels (as required)      | Check BACnet communications (../BAC only)              |
| Connecting Wallbus (if required)               | Connecting inputs and checking operation               |
| Powering up                                    | Connecting outputs and checking operation              |
| Setting up IP address parameters (if required) |  |

A full description of installing the unit is given in the IQ41x Installation Instructions - Mounting (TG201250) and IQ41x Installation Instructions - Configuring (TG201251).



## ORDER CODES

[Controller Type]/[LAN]/[BAC]/[Power]

[Controller Type]	IQ411	IQ411 controller with 3 universal inputs, 2 digital inputs, 6 solid state digital outputs
	IQ412	IQ412 controller with 3 universal inputs, 2 digital inputs, 4 solid state digital outputs, 2 analogue outputs,
[LAN]	Blank	No Trend current loop
	LAN	Trend current loop option fitted
[BAC]	Blank	No BACnet protocol
	BAC	BACnet over IP protocol capability option included
[Power]	230	230 Vac input power supply
	24VAC	24 Vac input power supply

Note: XML web services are fitted as standard in the IQ41x.

<b>IQ411/230</b>	IQ411 with Ethernet and 230 Vac supply
<b>IQ411/24VAC</b>	IQ411 with Ethernet and 24 Vac supply
<b>IQ411/LAN/230</b>	IQ411 with Ethernet, Trend current loop LAN and 230 Vac supply
<b>IQ411/LAN/24VAC</b>	IQ411 with Ethernet, Trend current loop LAN and 24 Vac supply
<b>IQ412/230</b>	IQ412 with Ethernet and 230 Vac supply
<b>IQ412/24/VAC</b>	IQ412 with Ethernet and 24 Vac supply
<b>IQ412/LAN/230</b>	IQ412 with Ethernet, Trend current loop LAN and 230 Vac supplyt
<b>IQ412/LAN/24/VAC</b>	IQ412 with Ethernet, Trend current loop LAN and 24 Vac supply
<b>IQ41x/xx/BAC/&lt;Power&gt;</b>	Any of the above with IP BACnet option

## ACCESSORIES

<b>IQ41x ADAPTOR PLATE/20</b>	:Retrofit mounting plate to facilitate replacement of IQ21x or IQ7x (Pack of 20)
<b>LAN CABLE EXTENDER/20</b>	:LAN cable extender to facilitate replacement of IQ21x or IQ7x (Pack of 20)



## SPECIFICATIONS

### ELECTRICAL

Power Input	
/230	:230 Vac $\pm$ 10% 50/60 Hz at up to 40 VA
/24VAC	:24 Vac $\pm$ 10% 50/60 Hz at up to 30 VA
Fusing	:No replaceable fuses required.
Power Failure Protection	
Strategy & data	:non-volatile flash memory.
Real time clock	:supercap, maintained for up to 8 days (typical).
Clock Accuracy	:10 s per month (typical).
Cycle Time	:Sequence table 1 s.

### Ethernet Network

Transmission	:10/100 BASE-T (IEEE 802.3).
Connection	:RJ45, auto MDI-X.
Cable Type:	:Cat 5e, UTP (unshielded twisted pair).
Distance (to hub)	:100 m (109 yds) maximum
Virtual CNCs	:1.
Address	:Not set by default – set to desired value in range 1 to 119 (excluding 2, 3, & 10) using configuration mode. Address must be unique on LAN.

### Current Loop (LAN variants only)

Transmission	:20 mA, two wire current loop, opto-isolated, polarity independent receiver, balanced transmitter.
Baud Rate	:1k2, 4k8, 9k6, 19k2 or 38k4; auto-detected (default) or settable in software.
Device Address	:1 to 119, (2, 3 and 10 not permitted) settable in software.
LAN number	:1 to 119, (2, 3 and 10 not permitted) settable in software.
Distance (node to node)	:dependent on cable type and baud rate (see table below):

Cable	Type	Baud Rate				
		1k2	4k8	9k6	19k2	38k4
Trend TP/2/2/22/ HF/200 Belden 8723	Shielded twisted pair 2 pairs (4 conductors)				700 m (765 yds)	350 m (380 yds)
Trend TP/1/1/22/ HF/200 Belden 8761	Shielded twisted pair 1 pair (2 conductors)	1000 m (1090 yds)				
Belden 9182 Belden 9207	Twinaxial (2 conductors)					

Note: Adjacent devices may specify different maximum cable lengths and baud rates. The shortest cable length (for the chosen baud rate) applies when connecting to the IQ41x current loop.

### RS232 Local Supervisor Port

Transmission	:RS232, EIA/TIA/232E, V28 supports Trend System comms
Distance	:15 m (16 yards) maximum
Supply	
/230	21 Vdc $\pm$ 5%; 60 mA maximum
/24VAC	Supply is unregulated and will vary with supply voltage and controller loading between 17 to 35 V; 60 mA maximum*.
Baud Rate	:9k6.
Address (sCNC1)	:1 to 119, (2, 3 and 10 not permitted) settable in software.

### Wallbus

Cable type	:Unscreened twisted pair.
Distance	:60 m (200 ft) maximum.
Supply Current	:50 mA maximum*.
Number of Devices	:up to 14 (subject to power loading)

### USB Local Engineering Port

Transmission	:USB 2.0.
Data Rate	:480 Mbits/s (Hi-Speed)
Distance	:5 m (5 yards) maximum.
Address (sCNC2)	:1 to 119, (2, 3 and 10 not permitted) settable in software.

### Inputs/Outputs

Number of Channels	
IQ411	:3 universal inputs, 2 digital inputs, 6 solid state digital outputs
IQ412	:3 universal inputs, 2 digital inputs, 2 analogue outputs, 4 solid state digital outputs

### Universal Inputs

Function	:Measuring voltage, current, thermistor or digital input (function set by strategy).
Input Noise Rejection	:Minimum 60 dB series mode rejection at input power supply frequency.
Input Resolution	:12 bit (4096 steps).
Voltage Input	
Input range	:0 to 10 V.
Input resistance	:9.4 k $\Omega$ .
Accuracy	: $\pm$ 0.5% of span (50 mV).
Current Input	
Input range	:0 to 20 mA.
Input resistance	:120 $\Omega$ .
Accuracy	: $\pm$ 0.5% of span (100 $\mu$ A).
Thermistor Input	
Temperature (NTC)	10 k $\Omega$ @ 25°C (77°F))
Input range	:-40 to 110°C (-40°F to 230°F)
Accuracy	: $\pm$ 0.3°C (-20°C to 90°C (-4°F to 194°F)); $\pm$ 0.4°C (<-20°C (-4°F) or >90°C (194°F))
Resistance	
Input range	:0 to 200 k $\Omega$
Accuracy	:1% of measured value or 10 $\Omega$ , whichever is the greater.
Bridge resistor	:12.2 k $\Omega$ .
Bridge supply	:3.3 V.
Digital Input	
Input voltage	:0 to 5 Vdc typical (50 Vdc maximum).
ON state	:<2.5 V @ 270 $\mu$ A (sink).
OFF state	:>3.5 V (or open circuit).
Count rate	:30 Hz max. (pulse width $\geq$ 16.6 ms).

### Digital Inputs

Function	:Detection of volt-free contact operation or open collector/drain type sources.
Input Voltage	:0 to 5 Vdc typical (50 Vdc maximum).
ON state	:<2.5 V @ 2.5 mA (sink).
OFF state	:>3.5 V (or open circuit).
Count Rate	:30 Hz max. (pulse width $\geq$ 16.6 ms).

### Analogue Outputs

Function	:Variable control from strategy of valve/damper actuators, voltage to current/pressure converters, relay modules, lighting dimmers, etc.
Voltage Range	:0 to 10 Vdc.
Current (maximum)	:up to 20 mA* (source). Maximum 18 mA* above 40°C (104°F).
Accuracy	: $\pm$ 0.5% of span.
Resolution	:11 bit (2048 steps).

### Auxiliary Supply Output

Voltage	:20 Vdc $\pm$ 10%.
Current (maximum)	:90 mA*.

\*Available current on /24VAC variants may be affected by demands on other outputs - see 'Combined Supply' on page 7.



## Inputs/Outputs (continued)

### Digital Outputs

Function: Switched 24 Vac control of thermic (thermoelectric) actuators, relays and synchronous motors\*.

#### /24VAC variants

Voltage :24 Vac  
Current :500 mA maximum per channel, 500 mA maximum total between all channels.

#### /230 variants

Voltage :24 Vac (synthesised)\*  
Current 300 mA maximum per channel, 300 mA maximum total between all channels.

\*Check suitability of load type - see page 6.

## INDICATORS

Power (⚡) :Green LED  
Watchdog (🐕) :Red LED  
LAN OK (📶) :Green LED  
Service Button (🔧) :Yellow LED  
RX (current loop) :Yellow LED  
TX (current loop) :Yellow LED  
OK (Ethernet) :Green LED  
RX (Ethernet) :Yellow LED

## MECHANICAL

Dimensions (WxHxD) :116 mm (4.57") x 157.5 mm (6.2") x 58.5 mm (2.3").

#### Material

Main body :Flame Retardant Polycarbonate (white)  
Terminal covers :Flame Retardant Polycarbonate (translucent orange).

#### Weight

/24VAC :0.317 kg (0.69 lb)  
/230 :0.342 kg (0.77 lb)

## Connectors

### Power

Connector type :2 part connector with rising cage clamp screw terminals.

Cable size :0.14 to 2.5 mm<sup>2</sup> (22 to 12 AWG).  
For UL compliance the input power connections must be made using 18 AWG or larger wire rated at least 90°C (194°F).

### Inputs/Outputs, Current Loop, Wallbus & AUX (power out)

Connector type :2 part connector (0.2" pitch) with rising cage clamp screw terminals.

Cable size :0.14 to 2.5 mm<sup>2</sup> (22 to 12 AWG)  
For UL compliance use copper cable only.

RS232 Supervisor Port :RJ11 (FCC68).

Ethernet Port :RJ45 connector.

USB Engineering Port :Micro B connector.

EMC :EN61326-1:2006  
Immunity :Table 2 - for equipment intended for use in industrial locations  
Emissions :Class B  
Safety :EN61010-1:2010  
CB certificates  
/230 :NO70277  
/24VAC :NO71191  
USA/Canada :/24VAC variants are UL rated as 'UL916, listed open energy management equipment.  
Canada :CSA22.2 No. 205-M1983 - Signal Equipment.

### Ambient Limits

Storage :-25°C (-13°F) to +60°C (+140°F)  
Operating :-25°C (-13°F) to +55°C (+131°F).

*Note: For /230 variants mounted vertically with the power connector end at the top the maximum operating temperature is 40°C (104°F) - see page 7. For temperatures below 0°C (32°F) special care must be taken that there is no condensation on or within the unit.*

Humidity :0 to 90% RH non-condensing  
Altitude :<4000 m (13124')  
Pollution Degree 2 (Only non-conducting pollution occurs)

### Protection

/230 :IP20 if mounted in an enclosure rated at IP20 or equivalent  
/24VAC :IP20

iPad and iPhone are trademarks of Apple Inc., registered in the U.S. and other countries. Android is a trademark of Google Inc. Windows is either a registered trademark or trademark of Microsoft Corporation in the United States and/or other countries

Please send any comments about this or any other Trend technical publication to [techpubs@trendcontrols.com](mailto:techpubs@trendcontrols.com)

© 2016 Honeywell Technologies Sàrl, ECC Division. All rights reserved. Manufactured for and on behalf of the Environmental and Combustion Controls Division of Honeywell Technologies Sàrl, Z.A. La Pièce, 16, 1180 Rolle, Switzerland by its Authorized Representative, Trend Control Systems Limited.

Trend Control Systems Limited reserves the right to revise this publication from time to time and make changes to the content hereof without obligation to notify any person of such revisions or changes.

## Trend Control Systems Limited

Albery House, Springfield Road, Horsham, West Sussex, RH12 2PQ, UK. Tel:+44 (0)1403 211888 Fax:+44 (0)1403 241608 [www.trendcontrols.com](http://www.trendcontrols.com)