

IQ4/IO Expansion Modules



Description

The IQ[®]4/IO range of DIN rail mounted I/O expansion modules are designed for use with IQ4E and IQ4NC/32/XNC controllers, offering additional input and output channel connection points. They are also compatible with, IQ3XCITE/96 and IQ3XCITE/128 controllers (v3.10 firmware onwards) and XCITE/IO modules.

IQ4/IO modules provide a comprehensive choice of I/O types including digital inputs (DI), universal inputs (UI), universal inputs/outputs (UIO), digital/relay outputs (DO) and analogue outputs (AO).

Modules can be located up to 300m (328 yards) from the controller.

Features

- 16DI, 8DI, 8UI, 8UIO, 4UIO, 8DO, 4DO and 8AO options
- Up to 30 I/O modules per controller (IQ4E & IQ4NC/32/XNC)
- Up to 192 I/O channels (with IQ4E, including controller I/O)
- Versatile I/O bus allows convenient placement of modules
- Up to 300m (328 yds I/O bus length (IQ4E & IQ4NC/32/XNC)
- Powered from controller I/O bus or external PSU
- Two part I/O connectors for easy installation/commissioning
- Small footprint with TS35 DIN rail mounting
- DIN 19 size 2 standard enclosure

Physical

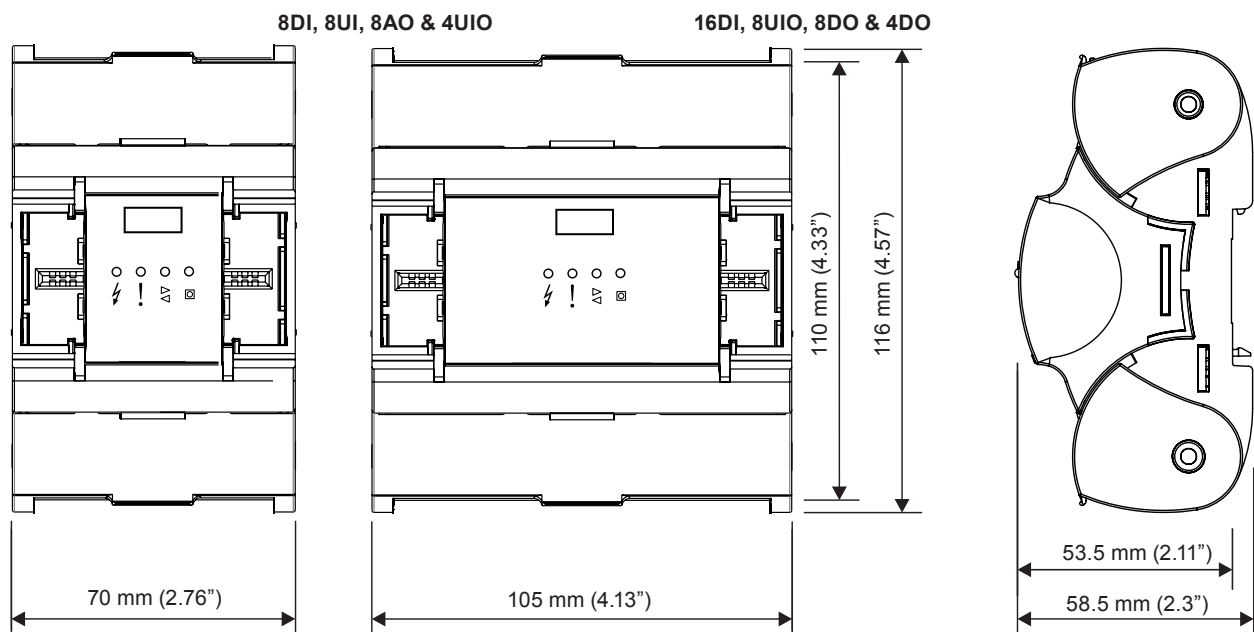

FUNCTIONALITY

HARDWARE

The range of IQ4/IO Expansion Modules comprises the following variants:

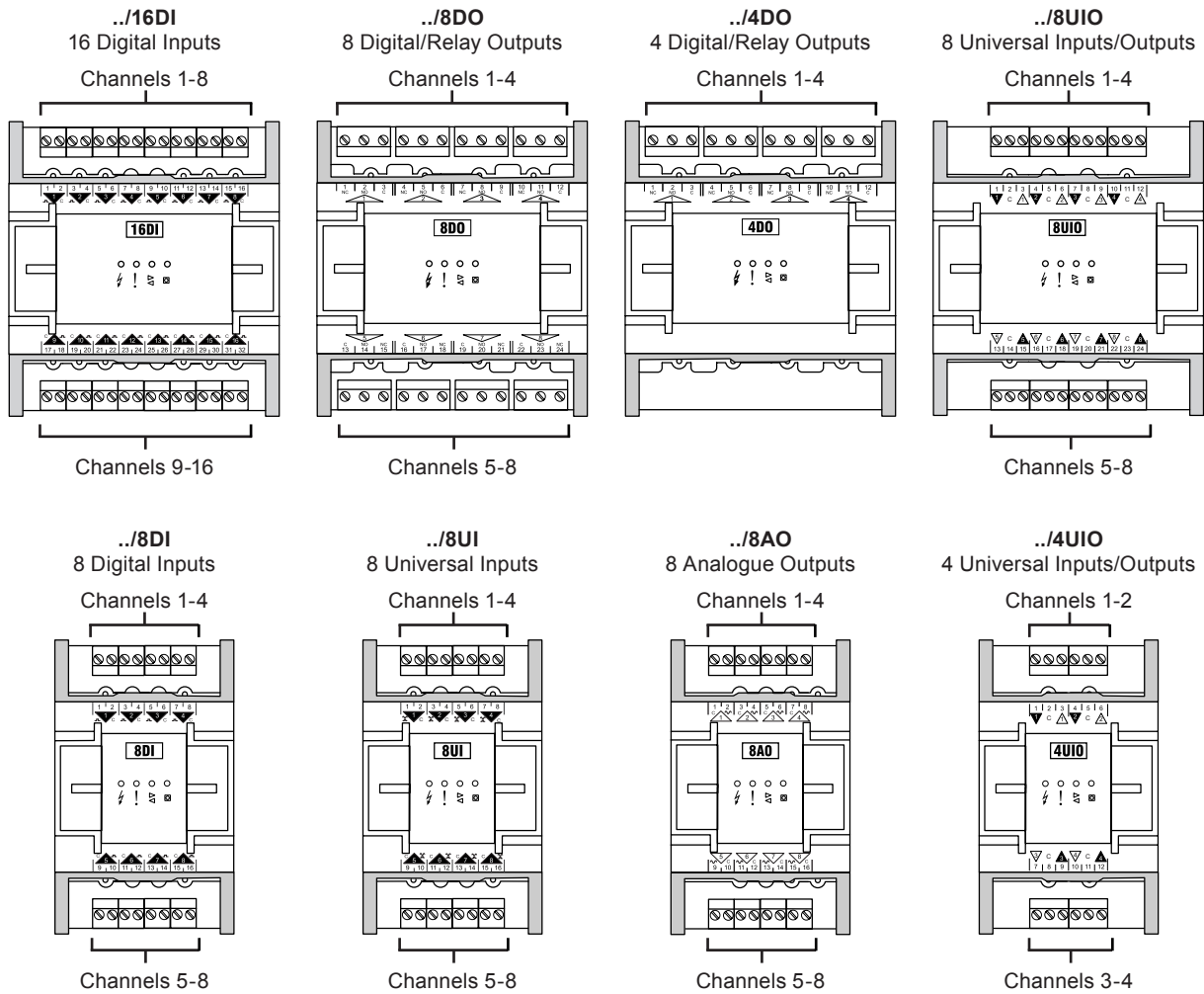

Enclosure

Each IQ4/IO Module is housed in a polycarbonate enclosure with a complimentary styling to the IQ4E controller. The modules come in one of two widths – 70 mm or 105 mm – depending on the variant.

Integral spring clips on the back of the module enable the unit to be clipped on to (and quickly released from) a standard TS35 DIN rail.

Rotating clear polycarbonate covers provide access for the top and bottom I/O channel connections.

IQ4/IO Modules must be installed in a secondary enclosure with a minimum protective rating of IP20 (or equivalent) or mounted outside normal reach (e.g. in a plenum).

A module may be mounted horizontally or vertically but not upside down or on its back:

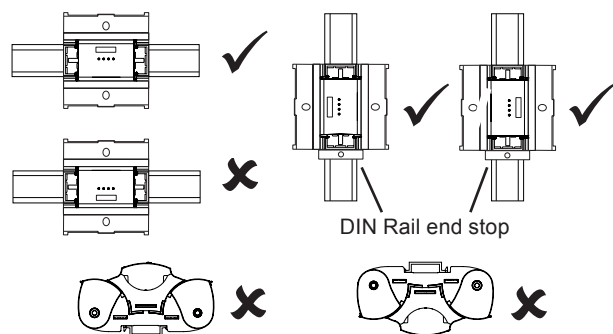

Input/Output Channels

The following types of input and output channel are supported:

- Universal Input/Output (UIO)
- Universal Input (UI)
- Digital Inputs (DI)
- Digital/Relay Output (DO)
- Analogue Outputs (AO)

Cable Screening

The use of screened cable for input and/or output connections is optional but not generally required unless the cable passes through electrically noisy environments.

If screened cable is used the screen must be connected to the local panel/enclosure ground and left unterminated at the far end.

Universal Input/Output (UIO)

These channels will function as one of the following according to the controller strategy:

- thermistor input,
- voltage input,
- digital input,
- current input, or
- analogue output.

The input or output function is set automatically by the strategy configuration in the controller.

Thermistor input: Used for a thermistor (NTC 10 kΩ @ 25°C (77°F), -40 to 110°C (-40°F to 230°F)), potentiometer (0 to 200 kΩ) or fan speed control. The thermistor bridge resistor is 12 kΩ with a bridge supply 3.3 V.

Example wiring

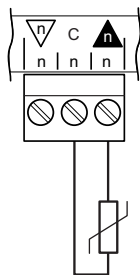

Voltage input: Used with a 0 to 10 Vdc source.

Example wiring

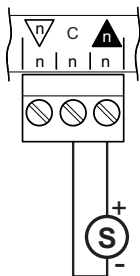

Digital input: Used for a volt free contact, logic circuit (e.g. TTL, CMOS), open collector (transistor) or open drain (FET).

Example wiring

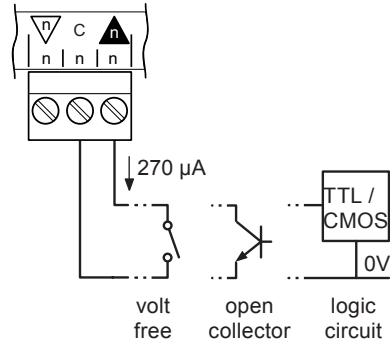

The volt free contact has a nominal wetting current of 270 μA. The input is ON when the contact is closed.

An open collector or open drain must be able to sink 270 μA. The input is ON when the transistor or FET conducts.

A logic circuit must be able to sink 270 μA. The input will be ON when the applied voltage is less than 2 Vdc (minimum 0 V). A voltage of greater than 3.5 Vdc (maximum 50 Vdc) will turn the input OFF. Voltage levels between 2 and 3.5 Vdc may cause indeterminate operation.

Current input: Used for 0 to 20 mA sources. May be either loop powered or externally powered according to which terminals are connected.

Example wiring - loop

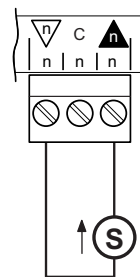

Example wiring - external

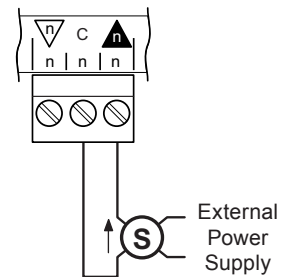

In loop powered mode the output terminal ∇ can source up to a maximum of 20 Vdc to power the sensor.

Note: With a sensor output current of 20 mA the voltage across the sensor will be at least 10 V if the module supply voltage is not less than 22V. If the sensor requires a higher minimum voltage it will be necessary to increase the module supply voltage, or power the sensor from an external supply.

Analogue output: Provides a variable voltage between 0 to 10 Vdc. The output can source up to 20 mA and sink up to 3 mA.

Example wiring

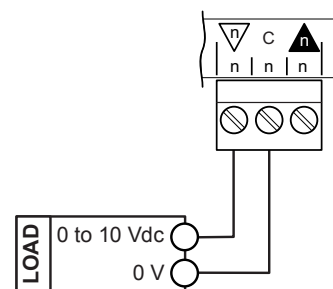

Universal Input (UI)

These channels will function as one of the following according to the controller strategy:

- voltage input,
- thermistor input,
- digital input, or
- current input.

Thermistor input: Used for a thermistor (NTC 10 kΩ @ 25°C (77°F), -40 to 110°C (-40°F to 230°F)), potentiometer (0 to 200 kΩ) or fan speed control. The thermistor bridge resistor is 12 kΩ with a bridge supply 3.3 V.

Example wiring

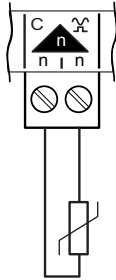

Voltage input: Used with a 0 to 10 Vdc source.

Example wiring

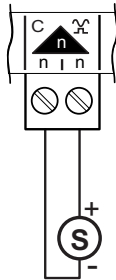

Digital input: Used for a volt free contact, logic circuit (e.g. TTL, CMOS), open collector (transistor) or open drain (FET).

Example wiring

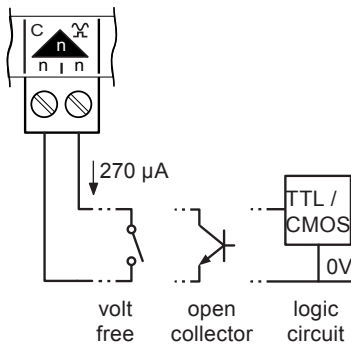

The volt free contact has a nominal wetting current of 270 μA. The input is ON when the contact is closed.

An open collector or open drain must be able to sink 270 μA. The input is ON when the transistor or FET conducts. Polarity must be observed.

A logic circuit must be able to sink 270 μA. The input will be ON when the voltage present on the input terminal is less than 2 Vdc (minimum 0V). A voltage greater than 3.5 Vdc (maximum 50 Vdc) or open circuit will turn the input OFF. Voltage levels between 2 and 3.5 Vdc may cause indeterminate operation.

Current input: Used for 0 to 20 mA sources which are externally powered.

Example wiring

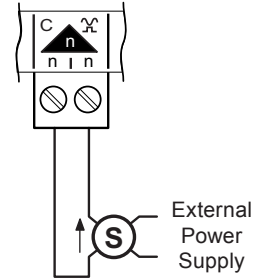

Digital Input (DI)

These channels are compatible with the following input devices:

- volt free contact (e.g. switch or relay),
- logic circuit (e.g. TTL, CMOS),
- open collector (transistor) or open drain (FET), or
- 24 Vac circuit.

Example wiring

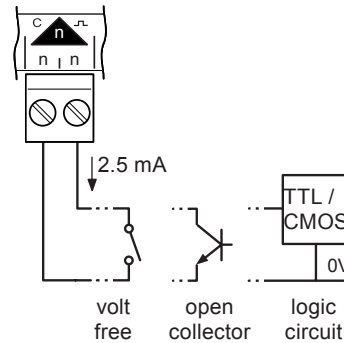

The volt free contact has a nominal wetting current of 2.5 mA. The input is ON when the contact is closed.

An open collector or open drain must be able to sink 2.5 mA. The input is ON when the transistor or FET conducts.

A logic circuit must be able to sink 2.5 mA. The input will be ON when the applied voltage is less than 2 Vdc (minimum 0 V). A voltage greater than 3.5 Vdc (maximum 50 Vdc) or open circuit will turn the input OFF. Voltage levels between 2 and 3.5 Vdc may cause indeterminate operation.

Digital inputs can also be used to monitor the state of a 24 Vac circuit (e.g. to determine if a relay or actuator is on or off).

Example wiring

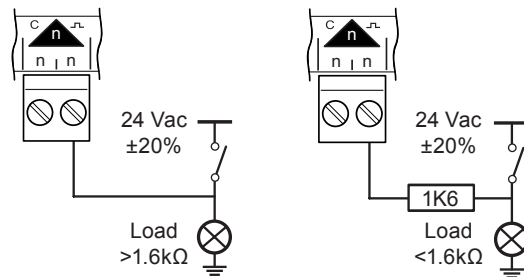

In the above example the input will be ON when the load is powered. If the load impedance is less than 1.6 kΩ (e.g. a filament lamp or relay coil) then a 1.6 kΩ resistor must be fitted in series with the input.

Analogue Output (AO)

Provides a variable voltage between 0 to 10 Vdc. The output can source up to 20mA and sink up to 3mA.

Example wiring

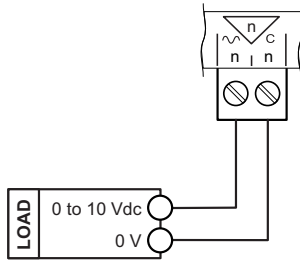

Digital/Relay Output (DO)

These channels provide a single pole dry contact changeover relay.

Example wiring

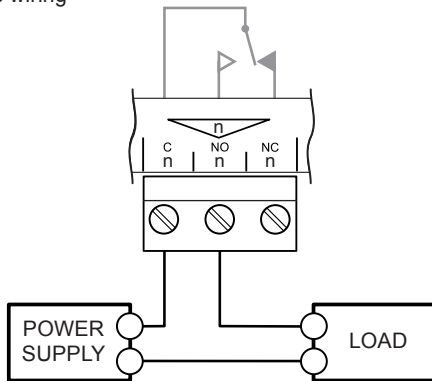

The relay contacts close (i.e. NO makes with C) when the output channel is ON.

I/O Bus

IQ4/IO modules interconnect with each other and the controller via the I/O bus, which comprises the following power and signal connections:

- +24 Vdc
- Data Hi
- Ground
- Data Lo
- 0 V

Access to the I/O bus on the IQ4E controller is via a connecting point located on the right-hand side of the unit.

Each IQ4/IO module has a similar connecting point on both the left and right-hand side, enabling the bus to be daisy-chained between modules.

A short rigid interconnector (IQ4/IC/LINK) is available to allow easy connection between adjacent modules. One interconnector is supplied with each I/O module; spare interconnectors are also available (see "Accessories" on page 10).

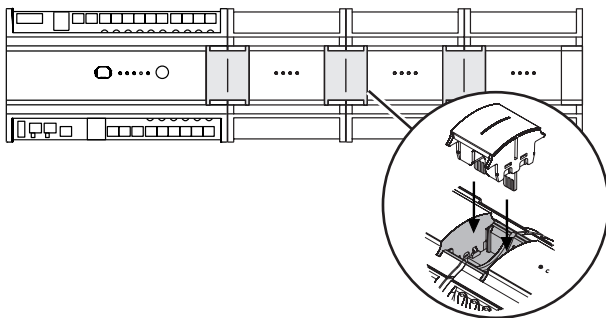

Note: Rigid interconnectors cannot be used between IQ4/IO modules and XCITE/IO modules or an IQ3/XCITE controller. In such cases a cabled interconnection must be used (see below).

Where modules are mounted separately from the controller (or from neighbouring I/O modules) the interconnection may be made using an IQ4/IC/ADPT cable adapter (see "Accessories" on page 10) and suitable screened cabling (see table below).

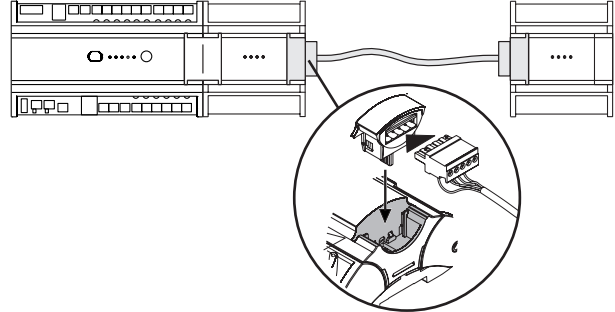

Note: The IQ4/IC/ADPT cable adapter includes non-replaceable fuses and Transient Voltage Suppression diodes that protect the I/O bus from over-current and over-voltage conditions caused by electrical transients or incorrect wiring.

Cabled interconnections can also be used to link IQ4/IO modules with XCITE/IO modules or an IQ3/XCITE controller.

Note: The XCITE/IO and IQ3/XCITE require a different cable adapter (see "Accessories" on page 10).

Between modules the I/O bus may be wired from right to left side (as shown above), right to right or left to left, as long as correct bus polarity is maintained. Spurs are not permitted.

Maximum I/O Bus Length

Where cabled interconnections are used the maximum I/O bus length is determined by the recommended cable type and the configuration of controller and modules used:

Product Configuration	Cable Type	
	Belden 3084A	Belden 7895A
IQ4E or IQ4NC/32/XNC with IQ4/IO modules only	total bus length up to 100 m (109 yards) or total bus length up to 300 m (328 yards) if IQ4/IO modules are within 100m (109 yards) of a power supply	total bus length up to 300 m (328 yards)
Any other combination using XCITE/IO modules or IQ3XCITE controller	total bus length up to 30 m (33 yards)*	

**Maximum 10 m (11 yards) for certain system configurations - for details check the XCITE/IO Modules Data Sheet (TA201352) and XCITE/IO Installation Instructions - Mounting (TG200627).*

For all installations, if the bus voltage at the I/O module drops below 19.2 V at full load, install another power supply at that module.

Maximum Number of Modules

Up to 30 modules can be connected to the I/O bus, depending on the configuration of controller and modules used:

Product Configuration	Maximum No. of Modules
IQ4E controller with IQ4/IO modules only	30
Any combination using XCITE/IO modules or IQ3XCITE controller	15

Note: Check that the controller supports the required number of I/O channels.

Bus Termination

The I/O bus must be terminated at the farthest end from the controller. A suitable plug-in terminator (IQ4/IC/TERM) is supplied with the IQ4E controller, and spare terminators are also available (see “Accessories” on page 10).

Earthing/Grounding Arrangements

It is important that correct earthing/grounding is provided for the controller and modules on the I/O bus.

The I/O bus ground is connected to earth/ground via the controller. Modules located within the same secondary enclosure are earthed/grounded via the I/O bus.

Where modules are located in different secondary enclosures or where I/O bus cables exceed 1 m (39”) a local earth/ground connection must be provided. For further details refer to the IQ4/IO Expansion Modules Installation Instructions - Mounting (TG201342).

All DIN rails must be earthed/grounded.

Module Power Supply

I/O modules are typically powered from the controller via the I/O bus. The bus supply is derived from the controller’s combined 24 Vdc supply and, therefore, the maximum current available to the I/O bus depends upon other current demands placed on the controller. For further details on the I/O bus current refer to the IQ4E Controller Data Sheet (TA201340) (for IQ4E and IQ4NC/..XNC) or IQ3 Controller Data Sheet (TA200505).

The maximum current required by each type of I/O module is listed in the table below – these values can be used to estimate the total current required by the I/O bus:

Module	Maximum Current Consumption
8UIO	30 mA
4UIO	+ 20 mA per loop-powered current input + up to 20 mA per analogue output
8UI	20 mA
16DI	40 mA (all inputs ON)
8DI	30 mA (all inputs ON)
8AO	20 mA + up to 20 mA per output
8DO	40 mA (all relays ON)
4DO	30 mA (all relays ON)

Where the total current requirement of the I/O bus exceeds the maximum available from the controller, one or more additional 24 Vdc power supplies may be installed.

Additional supplies may also be required in the following circumstances:

- at the end of a long I/O bus cable run, to prevent voltage drop on the bus supply,
- where the current flow through the power line of a module would exceed the maximum of 1 A, thus requiring the I/O bus power line to be split or segmented.

Additional Power Supplies

Important: Not permitted for UL compliant installations.

Where it is necessary to install an additional power supply along the I/O bus, the supply output must be isolated from earth (ground). The supply unit must also comply with the relevant EMC and safety standards.

Note: Trend offer a range of DIN rail mounted auxiliary power supplies that are suitable for this purpose.

Where the supply is required the normal 24 Vdc I/O bus connection between modules is not made. Instead the supply unit is wired between the 24 Vdc and 0 V terminals as shown below:

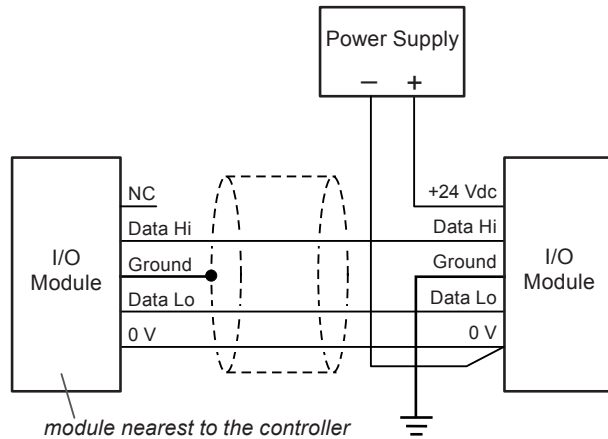

Important: The 0 V connection must be made when an external supply is used and the 0 V line must be continuous for the entire length of the I/O bus.

The standard cable adapter (IQ4/IC/ADPT) is used to make the connection of external power supply units to the I/O bus.

The following example shows a number of I/O modules split in to three groups, the first eight powered from the controller and the remaining two groups of four modules powered from external PSUs:

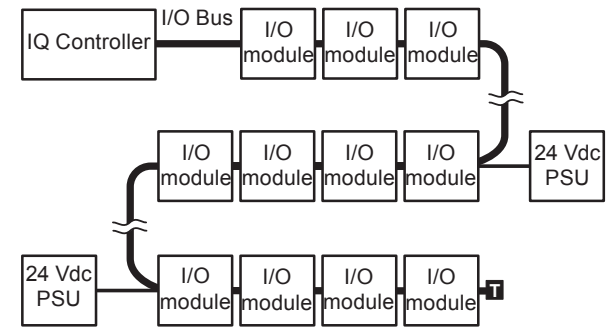

I/O Module Addressing

Each module on the I/O bus must be assigned a unique address (between 1 and 30).

The controller will automatically attempt to match each physical I/O module with its corresponding strategy I/O module and set its address accordingly.

Module addresses can be configured within the controller strategy, or manually changed using IQ®SET or the controller’s web page interface. Refer to the IQ4 Configuration Manual (TE201263) for further details on addressing.

Indicators

Various indicators are provided giving feedback on the operational status of the module and its inputs/outputs.

General Indicators (in centre of cover):

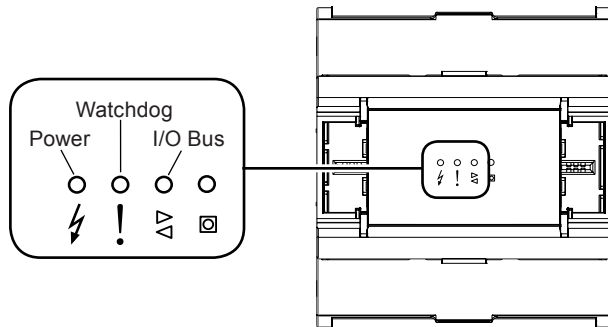

Indicator	Colour	Function
Power	Green	Condition of input power supply
Watchdog	Red	Warns of a firmware/strategy fault
I/O Bus	Green/Red	Status of I/O bus communication, including indication of module address and duplicate addresses.

Input/Output Indicators (adjacent to the appropriate I/O terminals and label, visible through rotating terminal covers):

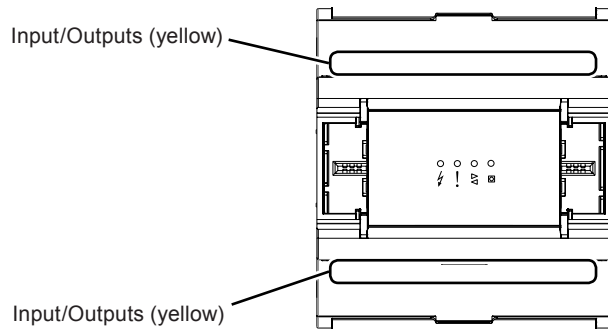

Indicator	Colour	Function
Digital Input	Yellow	On/Off state of associated input (applies to DI channels and UI or UIO channels in digital input mode)
Analogue Output	Yellow	Light intensity varies with output voltage (applies to AO channels and UIO channels in analogue output mode)
Digital / Relay Output	Yellow	On/Off state of associated input (applies to DO channels only)

Service Button

This is a multi-function button located on the front of the module:

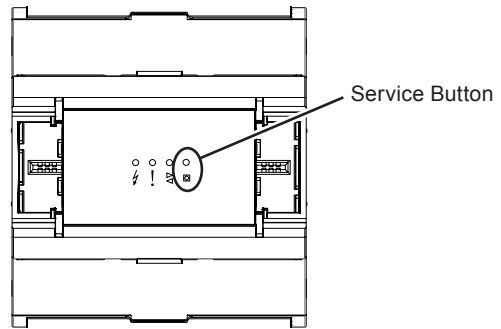

It can be used to:

- assign an unaddressed module to a strategy module (or next available bus address if a strategy module does not exist),
- display the module's address by flashing the I/O bus indicator, or
- perform a module reset (in conjunction with a power cycle).

FIELD MAINTENANCE

The IQ4/IO Expansion Modules require no routine maintenance.



WARNING: Contains no serviceable parts. Do not attempt to open the unit. Failure to comply may cause damage to the unit.

DISPOSAL

COSHH (Control of Substances Hazardous to Health - UK Government Regulations 2002) ASSESSMENT FOR DISPOSAL OF IQ4/IO Expansion Modules.

RECYCLING

All plastic and metal parts are recyclable. The printed circuit board may be sent to any PCB recovery contractor to recover some of the components for any metals such as gold and silver.



WEEE Directive:

At the end of their useful life the packaging, and product, and battery (if fitted) should be disposed of by a suitable recycling centre.

Do not dispose of with normal household waste.
Do not burn.

COMPATIBILITY

Controllers: IQ4E, IQ4NC/32/XNC, IQ3XCITE/96*, IQ3XCITE/128*.

I/O Modules: XCITE/IO.

*v3.10 firmware onwards.

INSTALLATION

The IQ4/IO Expansion Modules are designed to be clipped on to a standard TS35 DIN rail. They must be installed inside an enclosure rated to at least IP20 (or equivalent) or mounted outside normal reach (e.g. in a plenum). The modules are UL rated as 'UL60730 listed open energy management equipment'. The installation procedure involves:

- | | |
|--------------------------------------------------------|-------------------------------------------------|
| Mounting the I/O module(s) in position | Connecting analogue outputs (AO modules only) |
| Connecting the I/O bus | Connecting relay outputs (DO modules only) |
| Terminating the I/O bus | Isolating all I/O connections |
| Connecting additional PSUs (if required) | Downloading strategy to controller |
| Connecting universal inputs/outputs (UIO modules only) | Reconnecting all inputs and checking operation |
| Connecting universal inputs (UI modules only) | Reconnecting all outputs and checking operation |
| Connecting digital inputs (DI modules only) | |

A full description of installing the IQ4/IO modules is given in the IQ4/IO Expansion Modules Installation Instructions - Mounting (TG201342) and IQ4/IO Expansion Modules Installation Instructions - Configuring (TG201343).

ORDER CODES

IQ4/IO/16DI	I/O Module with 16 digital input channels
IQ4/IO/8DO	I/O Module with 8 digital/relay output channels
IQ4/IO/4DO	I/O Module with 4 digital/relay output channels
IQ4/IO/8UIO	I/O Module with 8 universal input/output channels
IQ4/IO/8DI	I/O Module with 8 digital inputs.
IQ4/IO/8UI	I/O Module with 8 universal inputs.
IQ4/IO/8AO	I/O Module with 8 analogue outputs.
IQ4/IO/4UIO	I/O Module with 4 universal inputs/outputs.

ACCESSORIES

IQ4/IC/TERM/5	Pack of 5 spare I/O bus terminators (for IQ4/IO modules, IQ4E controller, and IQ4NC/32/XNC)
IQ4/IC/LINK/5	Pack of 5 spare rigid I/O bus interconnectors (for IQ4/IO modules, IQ4E controller, and IQ4NC/32/XNC)
IQ4/IC/ADPT/10	Pack of 10 I/O bus cable adapters (for IQ4/IO modules, IQ4E controller, and IQ4NC/32/XNC)
XCITE/CC/10	Pack of 10 I/O bus cable adapters (for XCITE/IO modules and IQ3 controller)

SPECIFICATION

ELECTRICAL

Supply Voltage	:24 Vdc +10/-20%, derived from I/O bus or optional external isolated output power source.
Supply Current	:dependant on module type and input/output usage (see page 6). Maximum current flow through module on I/O bus = 1 A.
I/O Bus	
Max. total length	:300 m (328 yds), using IQ4E or IQ4NC/32/XNC and IQ4/IO modules only; 30 m (33 yds), using IQ3XCITE controller or XCITE/IO modules.
Max. modules	:30, using IQ4E or IQ4NC/32/XNC and IQ4/IO modules only; 15, using IQ3XCITE controller or XCITE/IO modules.

Inputs/Outputs

Universal Input/Output (UIO)

Function	:Measuring voltage, current, thermistor or digital input, or provide analogue control output (function set by strategy).
Input Noise Rejection	:Minimum 60 dB series mode rejection at input power supply frequency.
Voltage Input	
Input range	:0 to 10 Vdc.
Input resistance	:9.4 k Ω .
Accuracy	: \pm 0.5% of span (50 mV).
Current Input	
Input range	:0 to 20 mA.
Current source	:I/O bus (loop power) or external PSU.
Input resistance	:120 Ω .
Accuracy	: \pm 0.5% of span (100 μ A).
Resolution	:12 bit (4096 steps).
Thermistor Input	
Temperature (NTC 10 k Ω @ 25°C (77°F))	
Input range	:-40 to 110°C (-40°F to 230°F)
Accuracy	: \pm 0.3°C (-20°C to 90°C (-4°F to 194°F)); \pm 0.4°C (<-20°C (-4°F) or >90°C (194°F))
Resistance	
Input range	:0 to 200 k Ω
Accuracy	:1% of measured value or 10 Ω , whichever is the greater
Bridge resistor	:12.2 k Ω .
Bridge supply	:3.3 V.
Resolution	:12 bit (4096 steps).
Digital Input	
Input voltage	:0 to 5 Vdc typical (50 Vdc maximum).
ON state	:<2.5 Vdc @ 270 μ A (sink).
OFF state	:>3.5 Vdc (or open circuit).
Count rate	:30 Hz max. (pulse width \geq 16.6 ms).
Analogue Output	
Voltage range	:0 to 10 Vdc.
Current	:up to 20 mA (source) or 3 mA (sink).
Accuracy	: \pm 0.5% of span (50 mV).
Resolution	:11 bit (2048 steps).

Universal Inputs (UI)

Function	:Set by strategy to be voltage input, current input, thermistor input or digital input (volt free contact, open collector/drain or logic).
Input Noise Rejection	:Minimum 60 dB series mode rejection at input power supply frequency.
Voltage Input	:same as UIO (see above).
Current Input	:same as UIO (see above).
Thermistor Input	:same as UIO (see above).
Digital Input	:same as UIO (see above).

Digital Inputs (DI)

Function	:On/off state (or pulse count) to strategy from volt free contact, logic circuit (e.g. TTL, CMOS), open collector (transistor) or open drain (FET), or 24 Vac input.
Input Voltage	:0 to 5 Vdc typical (50 Vdc maximum).
ON state	:<2.5 V @ 2.5 mA (sink).
OFF state	:>3.5 V (or open circuit).
Count rate	:30 Hz max. (pulse width \geq 16.6 ms).

Analogue Outputs (AO)

Function	:Variable control from strategy of valve/damper actuators, voltage to current/pressure converters, relay modules, lighting dimmers, etc.
Voltage range	:0 to 10 Vdc.
Current	:up to 20 mA (source) or 3 mA (sink).
Resolution	:11 bit (2048 steps).
Accuracy	: \pm 0.5% of span.

Digital/Relay Outputs (DO)

Function	:Single pole changeover control from strategy for general purpose use.
Contact Rating	5 A @ 240 Vac (resistive); 5 A @ 30 Vdc (resistive).

Note: To meet safety requirements, relays being used must all be switching either low voltage or mains and not a mixture of voltages. If switching mains, they must all switch the same phase and polarity. Arc suppression circuit (RC) recommended for inductive loads (see TG200208). UL rating applies up to 240 Vac (120 VA) maximum.

INDICATORS

Power	:Green LED.
Watchdog	:Red LED.
I/O Bus	:Green/Red LED.
Inputs	:Yellow LED.
Outputs	:Yellow LED.

SPECIFICATION (continued)**MECHANICAL**

Dimensions (WxHxD)	
70 mm modules	:70 mm (2.76") x 116 mm (4.57") x 58.5 mm (2.3").
105 mm modules	:105 mm (4.13") x 116 mm (4.57") x 58.5 mm (2.3").
Material	
Main body	:Flame Retardant Polycarbonate (white)
Terminal covers	:Flame Retardant Polycarbonate (translucent orange).
Weight	
../16DI	:0.272 kg (0.60 lb);
../8DO	:0.299 kg (0.66 lb);
../4DO	:0.244 kg (0.54 lb);
../8UIO	:0.252 kg (0.56 lb);
../8DI	:0.185 kg (0.41 lb);
../8UI	:0.184 kg (0.41 lb);
../8AO	:0.187 kg (0.41 lb);
../4UIO	:0.175 kg (0.39 lb).
Mounting	:TS35 DIN Rail (EN500022).

Connectors

I/O Bus	:PCB edge connector for use with: IQ4/IC/LINK rigid interconnector, IQ4/IC/ADPT cable adapter, or IQ4/IC/TERM terminator.
Inputs/Outputs	:2 part connectors (0.2" pitch) with rising cage clamp screw terminals.
Cable size	:0.14 to 2.5 mm ² (22 to 12 AWG). <i>For UL compliance the input power connections must be made using 18 AWG or larger wire rated at least 90°C (194°F).</i>
Relay Outputs	:2 part connectors (0.3" pitch) with rising cage clamp screw terminals.
Cable size	:0.14 to 2.5 mm ² (22 to 12 AWG). <i>For UL compliance the input power connections must be made using 18 AWG or larger wire rated at least 90°C (194°F).</i>

ENVIRONMENTAL

EMC	:EN61326-1:2013.
Immunity	:Table 2 - for equipment intended for use in industrial locations.
Emissions	:Class B.
Safety	:EN61010-1:2010.
CB Certificate	:TBA.
USA/Canada	:UL rated as 'UL60730 listed open energy management equipment'.
Canada	:CSA22.2 No. 205-M1983 - Signal Equipment.
Ambient Limits	
Storage	:-25°C (-13°F) to +60°C (+140°F).
Operating	:-25°C (-13°F) to +55°C (+131°F).
<i>Note: For temperatures below 0°C (32°F) special care must be taken that there is no condensation on or within the unit.</i>	
Humidity	:0 to 90 %RH non-condensing.
Altitude	:<4000 m (13124').
Pollution Degree	:2 (only non-conducting pollution occurs).
Protection	:IP20.

Please send any comments about this or any other Trend technical publication to techpubs@trendcontrols.com

© 2016 Honeywell Technologies Sàrl, E&ES Division. All rights reserved. Manufactured for and on behalf of the Environmental and Combustion Controls Division of Honeywell Technologies Sàrl, Z.A. La Pièce, 16, 1180 Rolle, Switzerland by its Authorized Representative, Trend Control Systems Limited.

Trend Control Systems Limited reserves the right to revise this publication from time to time and make changes to the content hereof without obligation to notify any person of such revisions or changes.

Trend Control Systems Limited

Albery House, Springfield Road, Horsham, West Sussex, RH12 2PQ, UK. Tel:+44 (0)1403 211888 Fax:+44 (0)1403 241608 www.trendcontrols.com